

ISTRUZIONI DI MONTAGGIO / ASSEMBLING INSTRUCTIONS

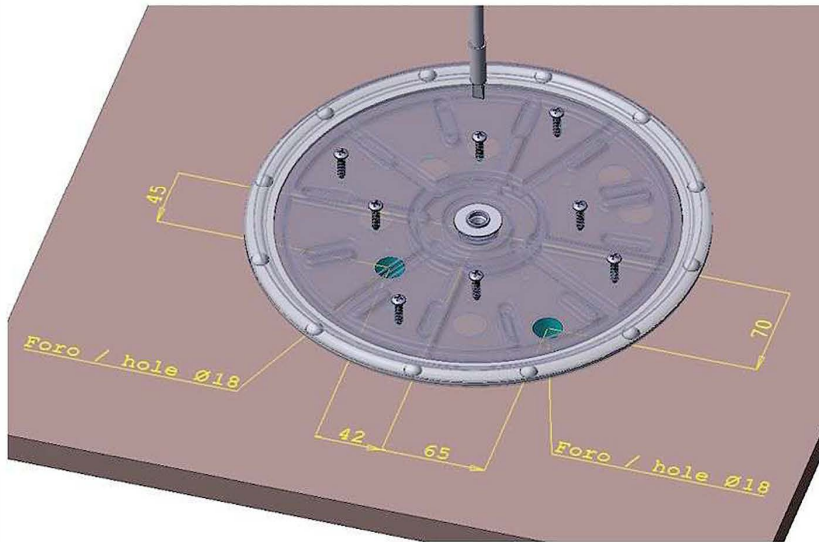

A

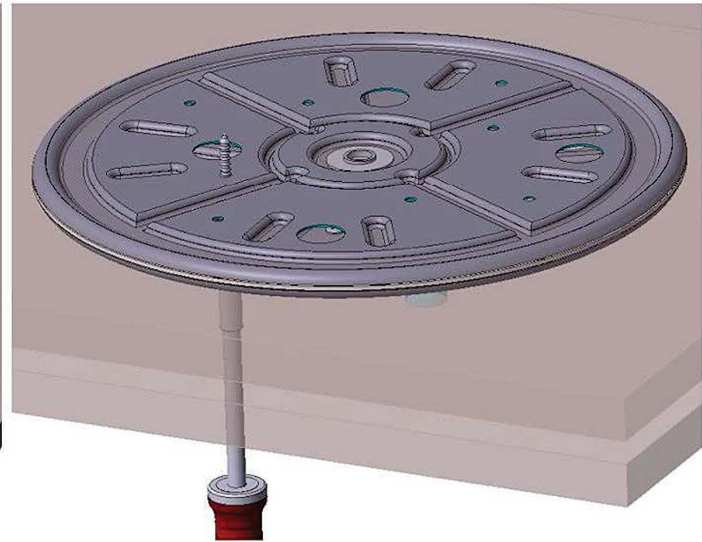

B

1. Fissare la piastra rotante sul piano inferiore fisso (A) attraverso i fori da 21 mm
2. Praticare due fori passanti da 18 mm sul piano inferiore fisso come da immagine A
3. Posizionare il piano superiore girevole sulla piastra
4. Ruotare il piano superiore fino a far coincidere i fori da 18 mm con i fori per le viti sulla piastra rotante (B)
5. Fissare la piastra al piano superiore attraverso i fori da 18 mm

1. Fix the rotating plate to the lower fixed panel (A) through the 21 mm holes
2. Drill two 18 mm through holes on the lower fixed panel as shown on image A
3. Place the upper panel on the rotating plate
4. Rotate the upper panel to make the 18 mm holes correspond with the screw holes of the rotating plate (B)
5. Fix the plate to the upper panel through the 18 mm holes on the lower panel