

CARATTERISTICHE • FEATURES • CARACTÉRISTIQUES • CARACTERÍSTICAS

Telaio estraibile in alluminio, con guide a chiusura ammortizzata.
 Pull out frame aluminium, slides with soft closing.
 Châssis en aluminium coulissant, avec glissières amortisseur.
 Marco de aluminio extraíble, con guías amortiguada.

MINUTERIA INTERNA • FITTINGS • FERRURE • FERRETERIA

N°12 4x16 mm Viti autofilettanti / Self-tapping screws / Vis auto-taraudeuses / Tornillos autorroscantes

COMPONENTI • PARTS • COMPOSANTS • COMPONENTES

- A. N°1 Telaio / Frame / Châssis / Marco
- B. N°1 Set guide / Slide kit / Kit Coulisses / Kit guías
- C. N°1 L.2.5m Guarnizione gomma / Rubber gasket / Joint en caoutchouc / Junta de goma
- D. N°1 Kit cover guide/ Kit slides cover/ Kit couvercle coulissant/Kit de cubierta de diapositivas

UTENSILERIA • TOOLS • OUTILS • INSTRUMENTOS



MANUTENZIONE • MAINTENANCE • ENTRETIEN • MANTENIMIENTO

Pulire con un panno morbido ed asciutto. Evitare l'uso di solventi e/o abrasivi.
 Clean with a soft, dry cloth. Avoid using solvents or abrasive.
 Nettoyez avec un chiffon sec et doux. N'utilisez aucun solvant ou produit abrasif.
 Limpiar con paño suave y seco. Evitar el uso de solventes y/o abrasivos.

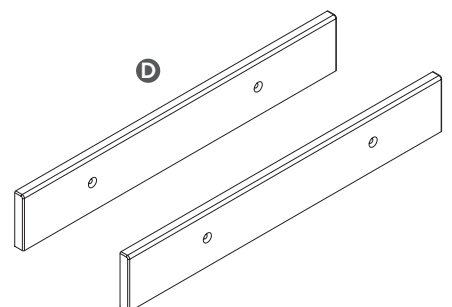
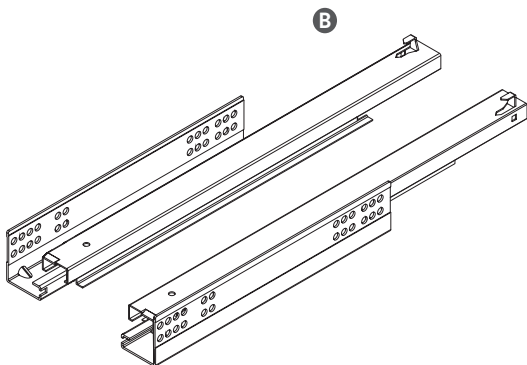
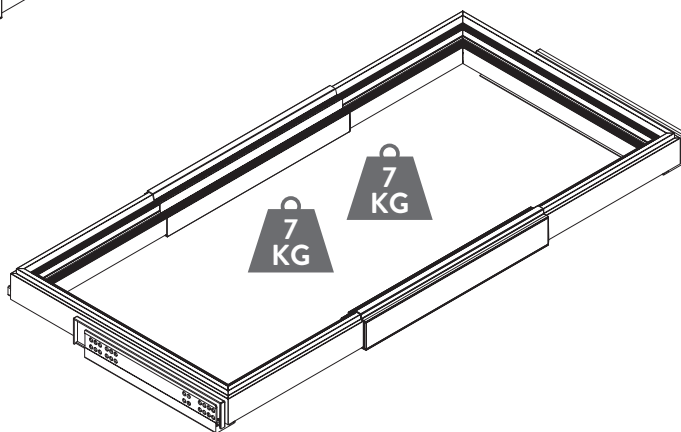
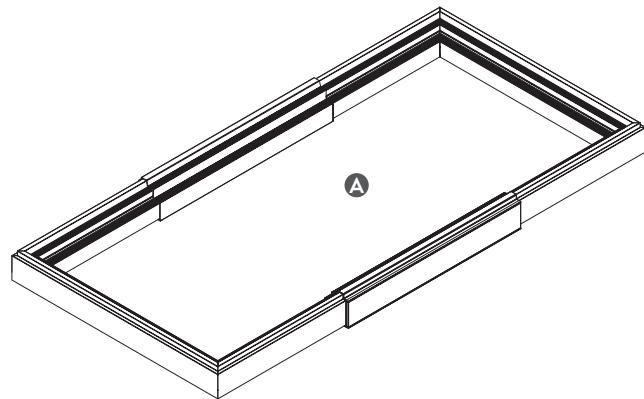
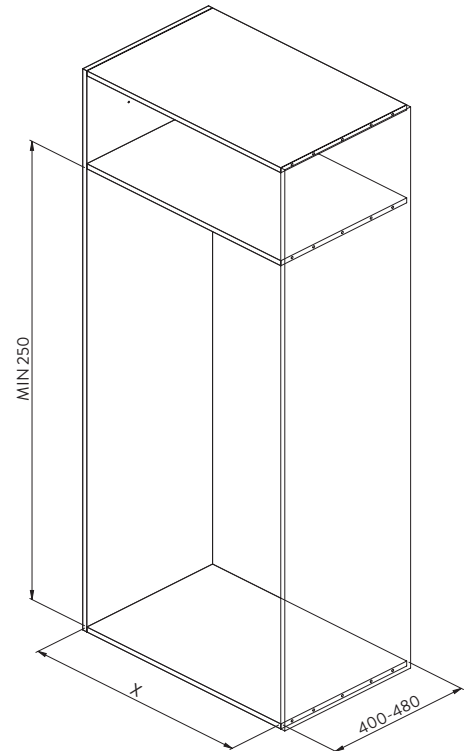

XMIN	XMAX
500	775
800	1075

1**N°12 4x16**

Avvitare le guide al fianco del mobile, rispettando le quote indicate, poi avvitare il copriguida come mostrato.

Screw the slides to the side of the cabinet respecting the indicated dimensions, then screw the guide cover as shown.

Vissez les glissières sur le côté du meuble en respectant les dimensions indiquées, puis vissez le couvercle du guide comme indiqué. Atornille las correderas al lateral del mueble respetando las dimensiones indicadas, luego atornille la cubierta de la guía como se muestra.

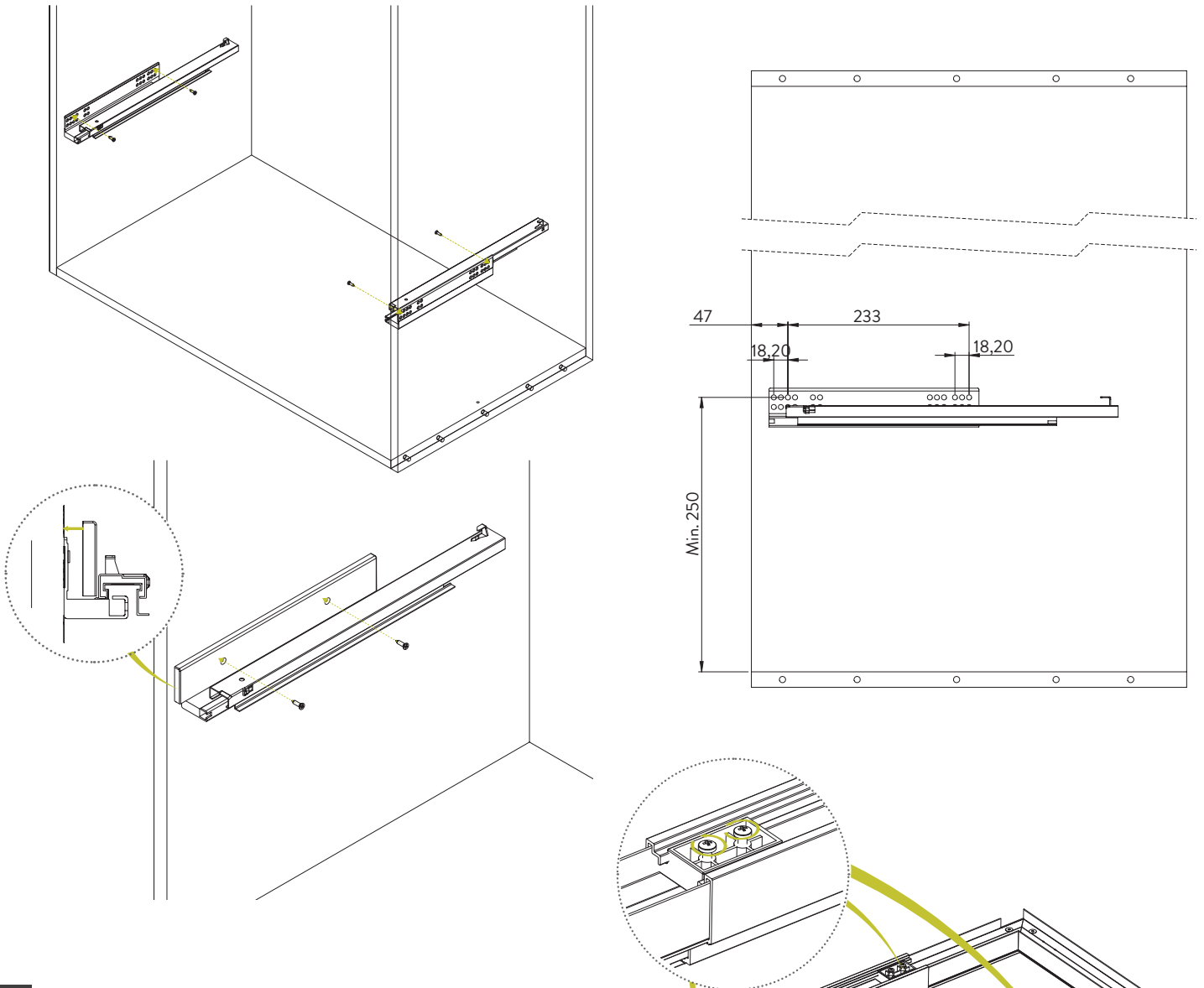
**2**

Posizionare il telaio su un piano e ruotarlo sottosopra. Svitare le viti dei supporti di bloccaggio, mettere il telaio a misura e riavvitare le viti.

Place the frame on a surface and rotate it upside down. Unscrew the screws of the locking supports, adjust the frame to size and retighten the screws.

Positionnez le cadre à plat et acheminez-le immédiatement. Si vous vérifiez les supports à visser, mettez le cadre à la bonne taille et vérifiez les données.

Coloque el marco sobre una superficie y gírelo boca abajo. Desenrosque los tornillos de los soportes de bloqueo, ajuste el marco al tamaño y vuelva a apretar los tornillos.

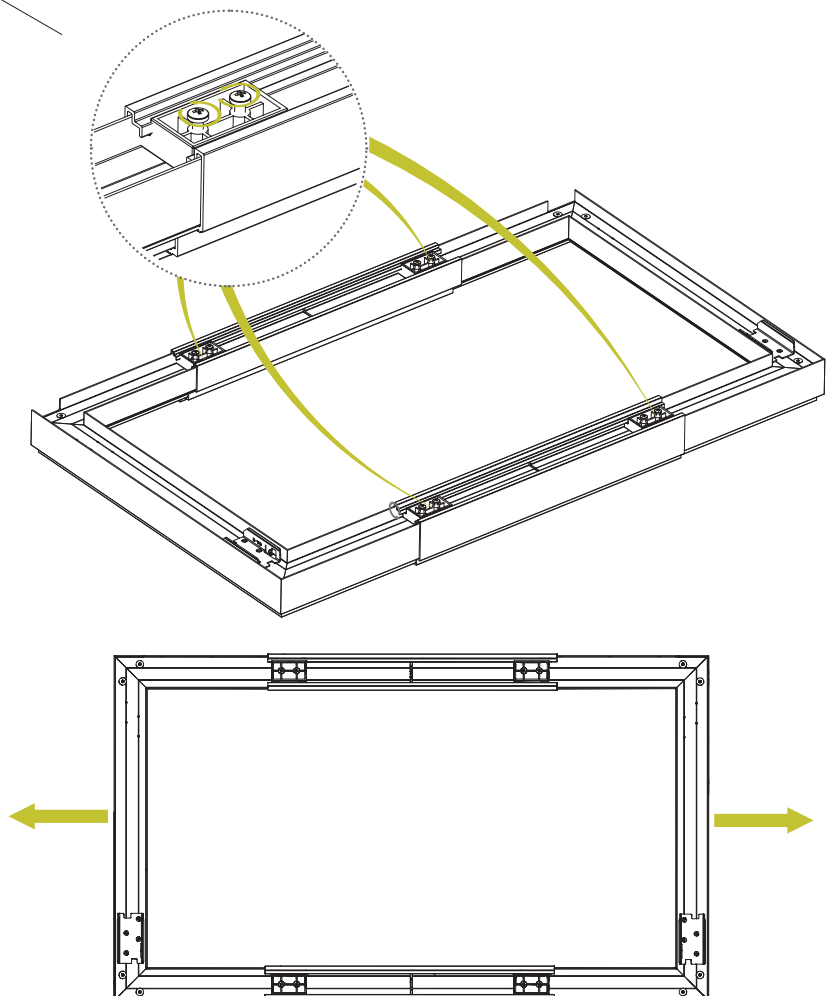

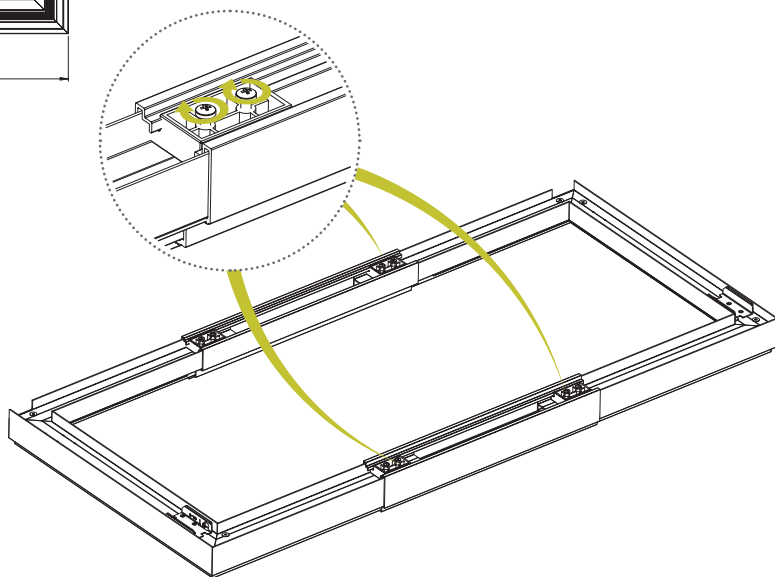
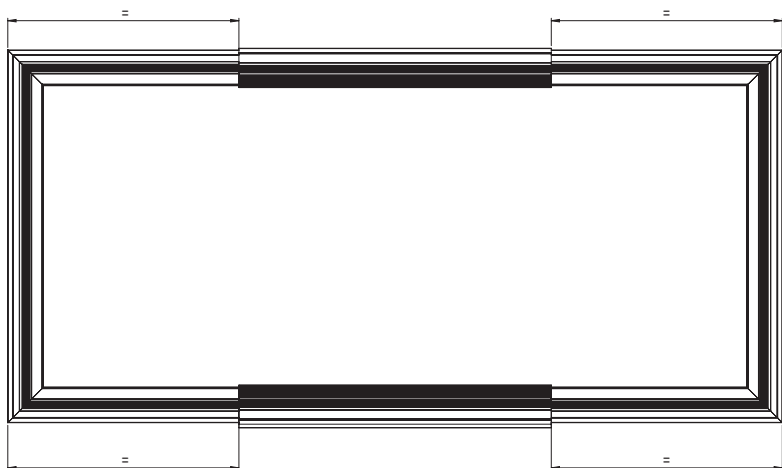

3

Agganciare il telaio alle guide.
Mount the frame on the slides.
Montez le cadre sur les coulisses.
Monte el marco en las diapositivas.

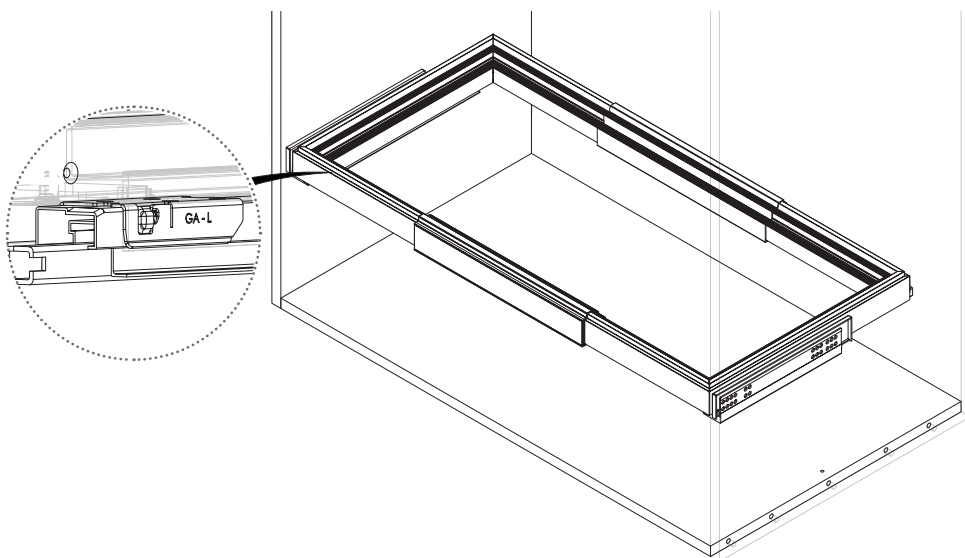
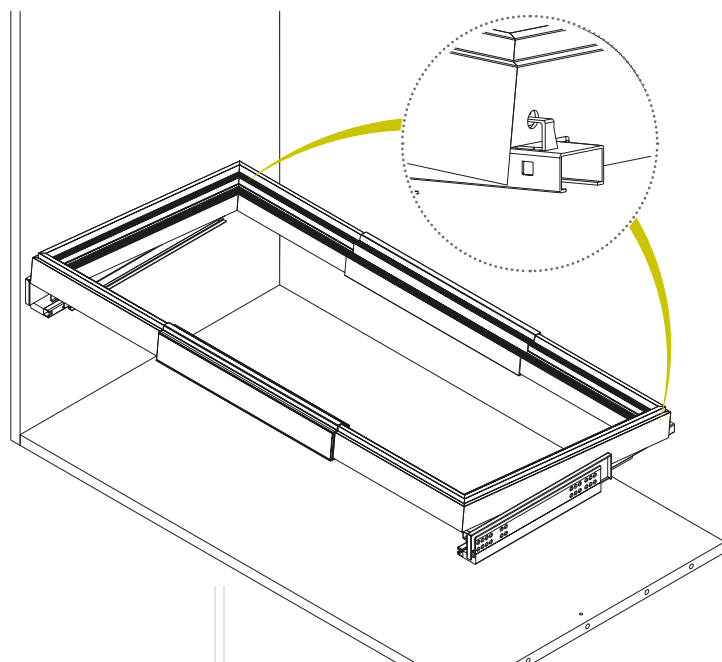



4

Tagliare le guarnizioni a misura ed incollarle nei profili del telaio.
Cut the gaskets to size and glue them into the frame profiles.
Découpez les joints sur mesure et collez-les dans les profilés du cadre.
Corta las juntas a medida y pégalas en los perfiles del marco.

