

Thank you for using our product. Before installation, please read this manual thoroughly to ensure correct installation. Please keep this manual at hand for future reference.



Video link



## ABOUT THE PRODUCT

- The Monoflat Unizon is a coplanar sliding door system.
- Built in soft closer, enables two-way soft closing movement in both direction.
- The mounting template makes it easy to determine the mounting position. Please download it from the product page and use it.

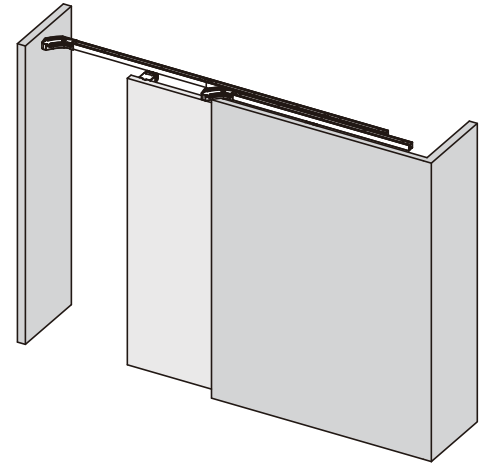
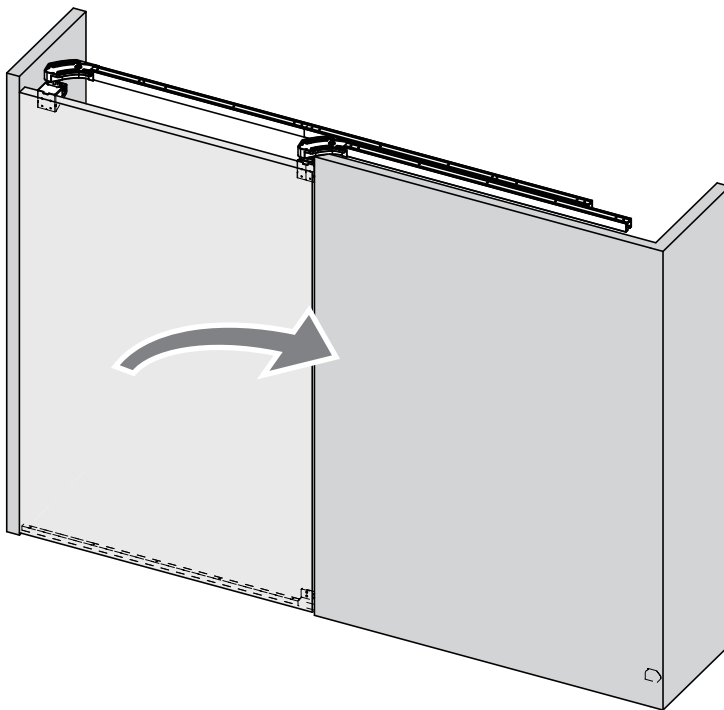

Mounting template



## SPECIFICATION

Item name		MFU1200-40	MFU1200-70
Door width		800 - 1200 mm	
Door height		MAX. 2700 mm	
Door thickness		30 - 40 mm	
Door weight		20 - 40 kg	40 - 70 kg
Adjustment range	Vertical	±4 mm	
	Front/Back	±4 mm	

• The recommended temperature range for use is 5°C to 40° C.





• The closing speed of the soft closing type door may change depending on the ambient temperature, operating method or installation quality.

## FOR YOUR SAFETY AND PROPER INSTALLATION





### Meaning of symbols

 <b>Warning Caution</b>	 <b>Prohibited</b>	 <b>Required</b>
--	---	---

 **Warning :** May result in serious injury if not followed properly.

-  This product should be installed by a qualified person in accordance with this manual. If it is not installed correctly, the door may fall and cause injury.
-  Provide a frame that can withstand the weight and impact of opening and closing the door. Be sure to use the specified screws and tighten them securely. If the mounting strength is insufficient, the door may fall and cause injury.
-  Do not use this product for any other purpose, or with doors that are outside the specifications of this manual.
-  Do not disassemble or modify any parts other than those described in this document.

 **Caution :** May result in injury or damage if not followed properly.

-  This product is a part for architectural fittings. After installation, please check the function and safety of the final product. Please inform the end user how to use the product safely.
-  Follow the specified dimensions, specifications, and alignment of the door and frame. Warping, tilting or twisting of the frame or door may cause failure.
-  If cutting any parts, make sure to remove any burrs before installation. Also check the upper tack for any left-over burrs or scraps and remove these.
-  Make sure to check the screws for slack at regular intervals (one month from first usage, half a year, and then one time every years is recommended).
-  Install the product with two people (in the case of one person, there is a risk of damaging components).

# PARTS LIST

Left to right opening is shown in the parts list and the installation drawing.

Set name		Item name		
Bracket set Left to Right opening		MFU1200-L-BL		
Bracket set Right to Left opening		MFU1200-R-BL		
(1) Guiding track (top)	(2) Guiding track (bottom)	(3) Bracket (for leading edge)	(4) Bracket (for trailing edge)	(5) Bottom guide
(6) Connecting plate	(7) Door stopper (floor)	(8) Bumper block	(9) Trigger	(10) Jig
(11) Bind head tapping screw 5 x 40	(12) Countersunk head tapping screw 4 x 40	(13) Countersunk head tapping screw 4 x 20(Black)	(14) Countersunk head tapping screw 4 x 30(φ6 head)	
For (1)	For (6)	For (5)	For (9)	
(15) Bind head tapping screw 5 x 20	(16) Pan head tapping screw 4 x 30	(17) Caution sticker		
For (2) (3) (4)	For (7)			

• As for right to Left opening, (1) and (2) will be mirror image.

Set name	Item name	(18) Soft closer(leading edge)	(19) Door roller(trailing edge)
Closer set 40 kg	MFU1200-40DSC-BL		
Closer set 70 kg	MFU1200-70DSC-BL		

※1 Do not remove the tape on the product.

Set name	Item name			
Rail set	MFU1200-RS-BL			
(20) Upper track A	(21) Upper track B	(22) Bottom track	(23) Bind head tapping screw 5 x 40	(24) Countersunk head tapping screw 4 x 20
1120 mm	850 mm	1100 mm	For (20)	For (22)

- Tools needed
- Phillips screwdriver : #2
  - Hex key(3 mm, 4 mm)
  - Spanner wrench(13 mm)
  - Support

■ Cover panel

Cover panels	Height	Width	Thickness
Front cover panel	60	Opening width	MAX. 13
Rear cover panel	60	FREE	FREE

# INSTALLATION DRAWING

Units: mm

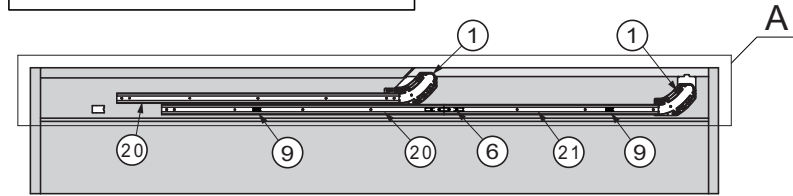
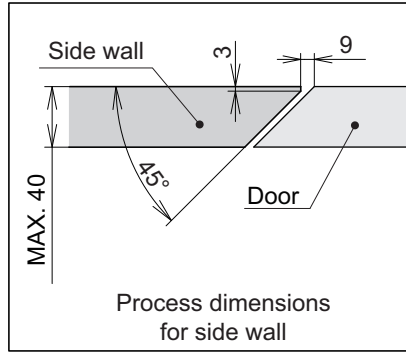
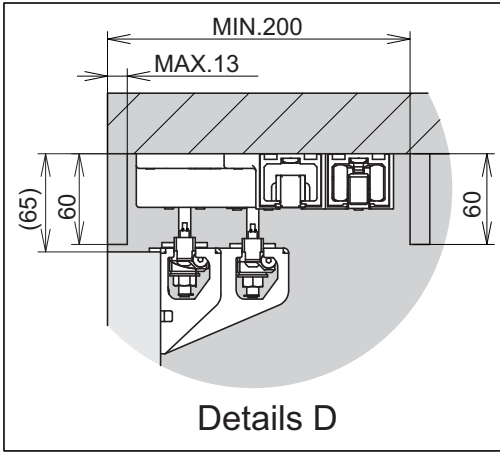

Frame opening width = Door width + Door width + 250 or more

(※3 Frame opening width = Door width + Door width + 75 or more)

(Available opening width = Door width - 50)

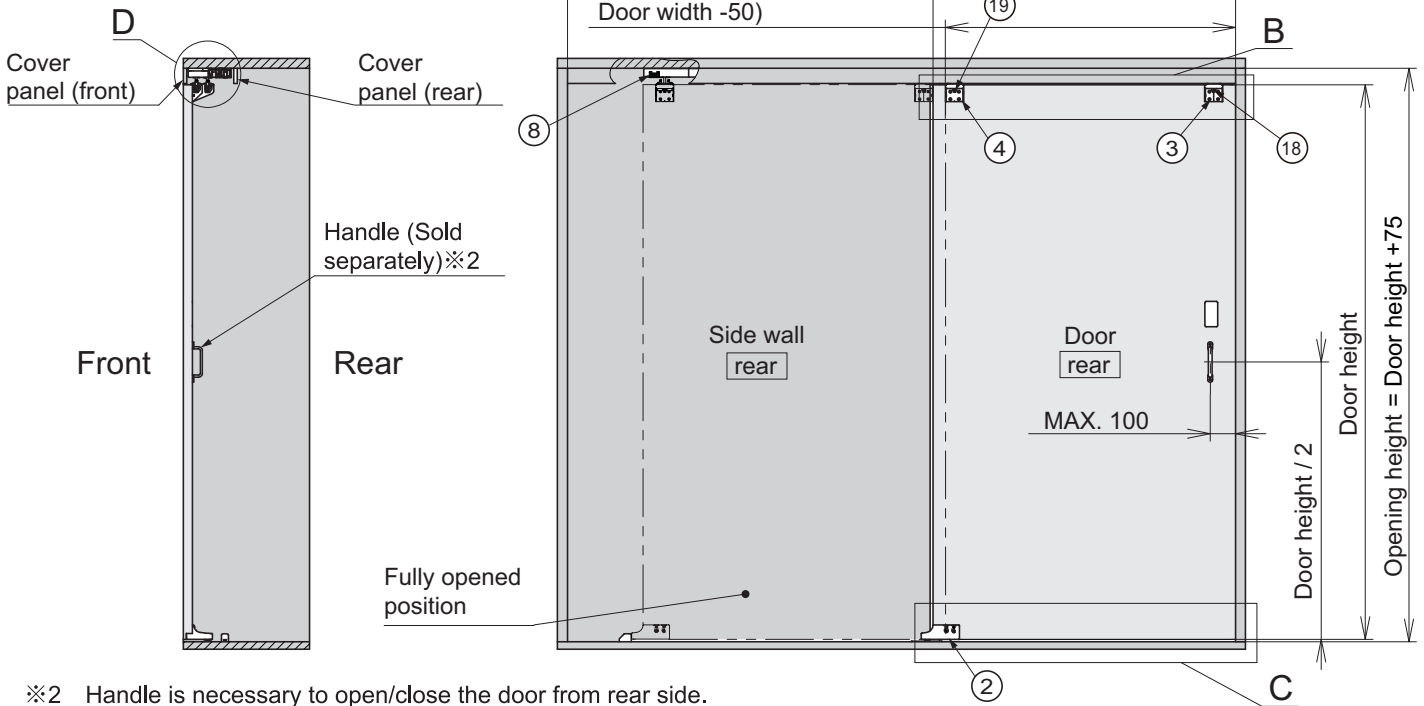

※2 Handle is necessary to open/close the door from rear side.

※3 When frame opening width is 1675 - 1849 mm.

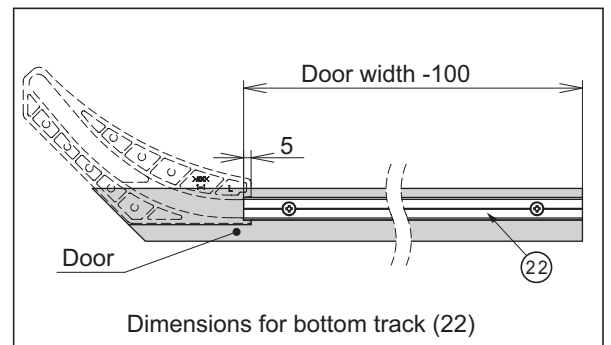
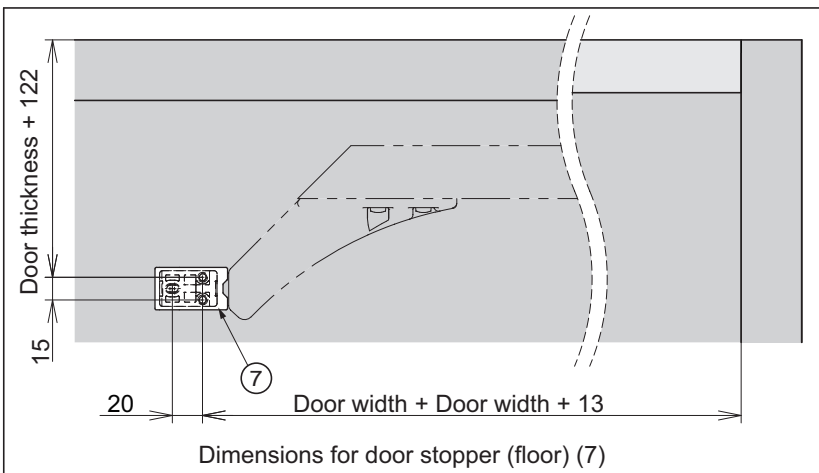

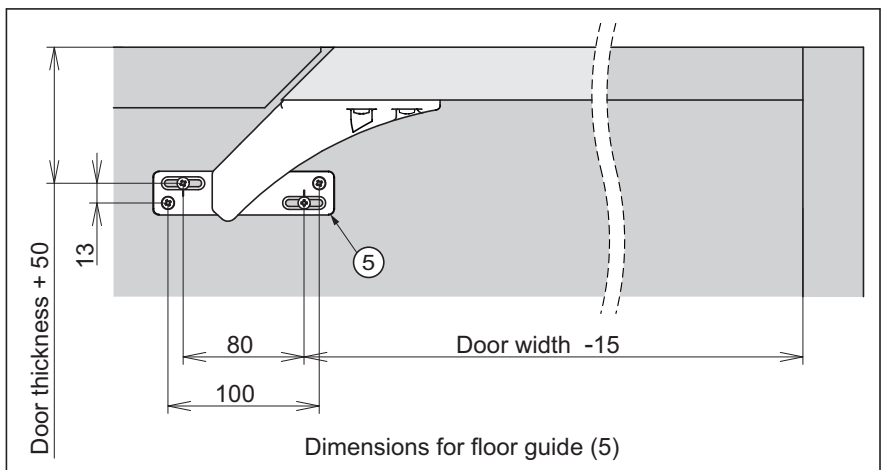
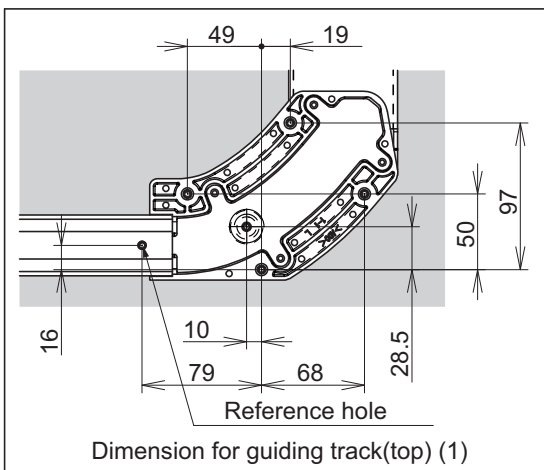
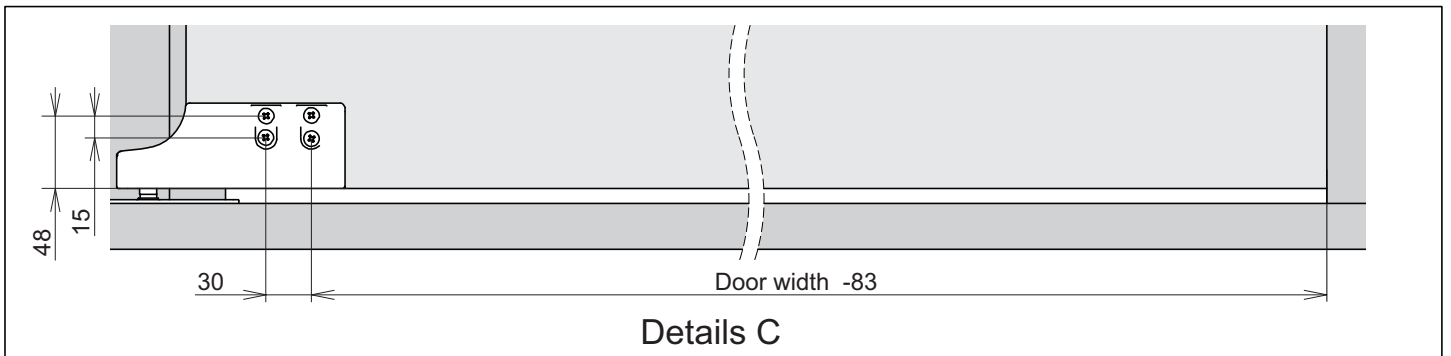
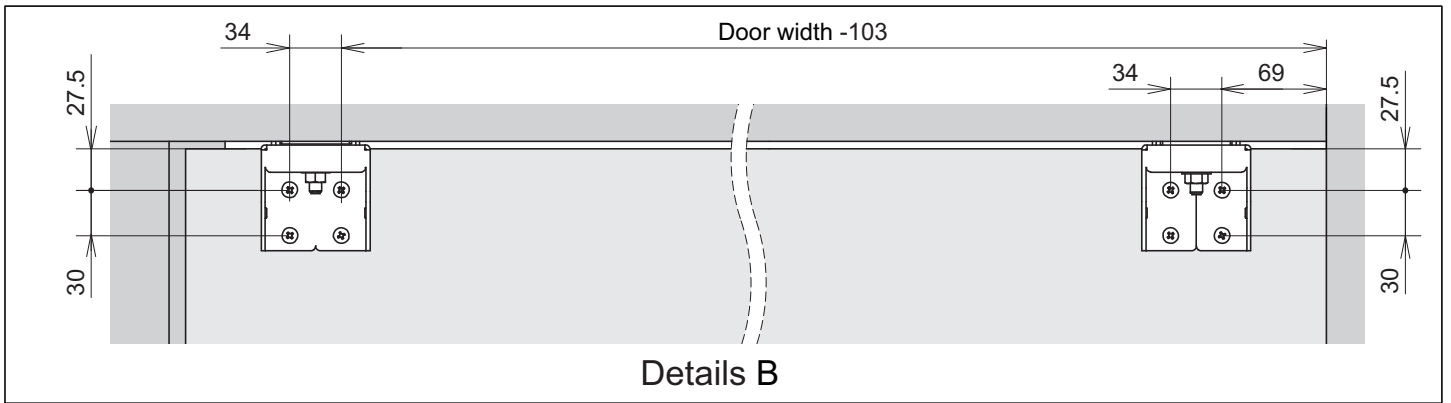
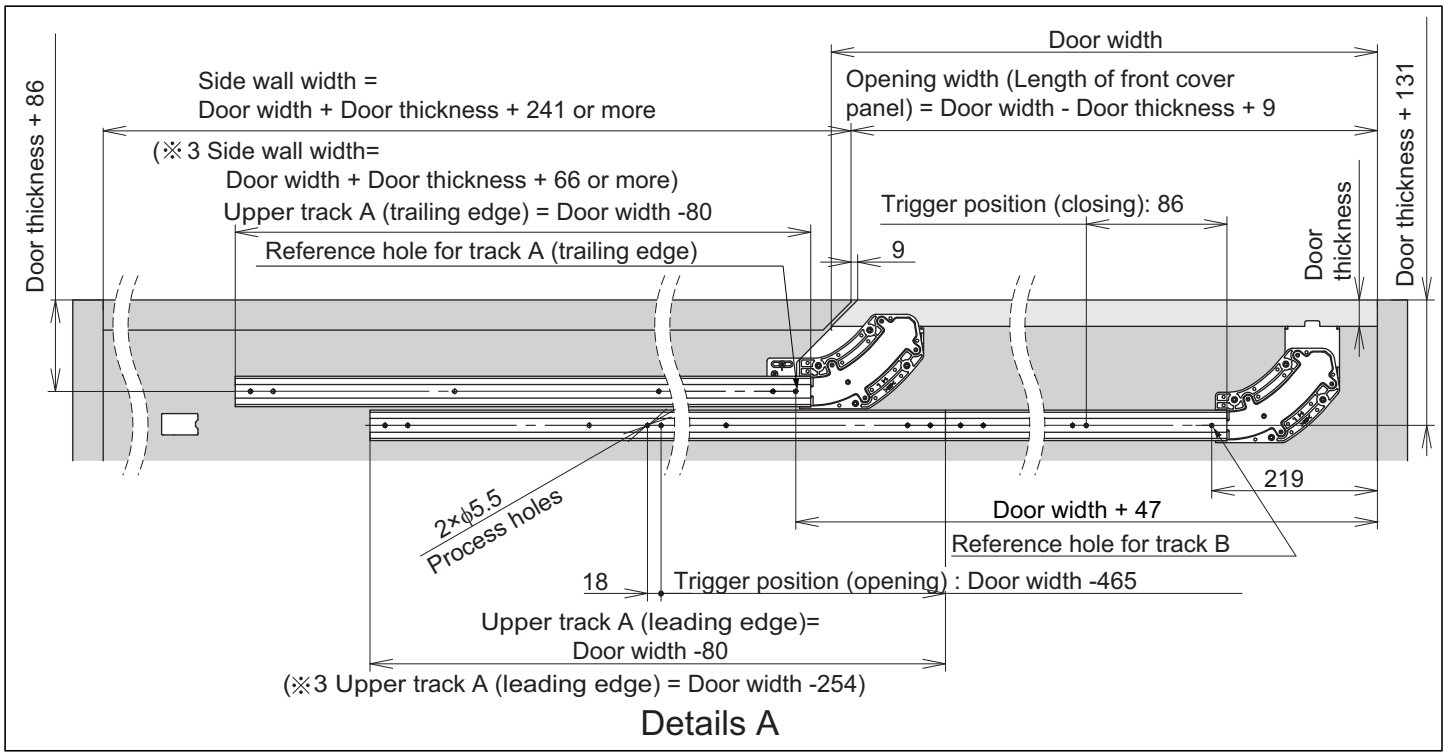

**CAUTION**

⚠ If the door is warped or the mounting position of the parts is incorrect, even if the door position is adjusted, it may not be flat with the side wall.

**Door process dimensions**

The below drawing shows the left to right opening type.

Units: mm

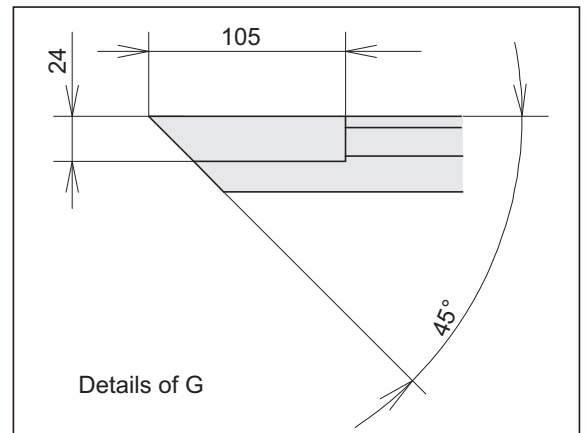
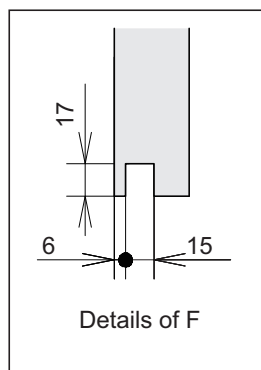
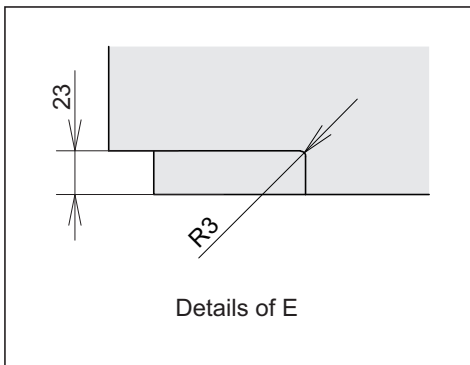
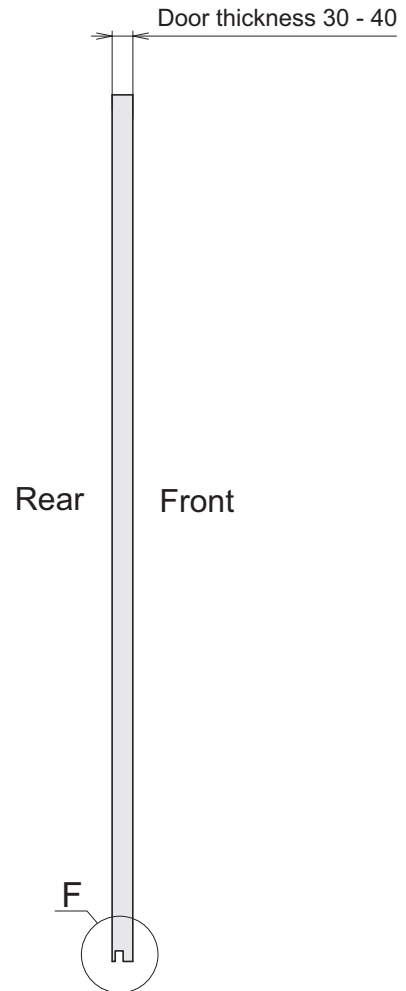
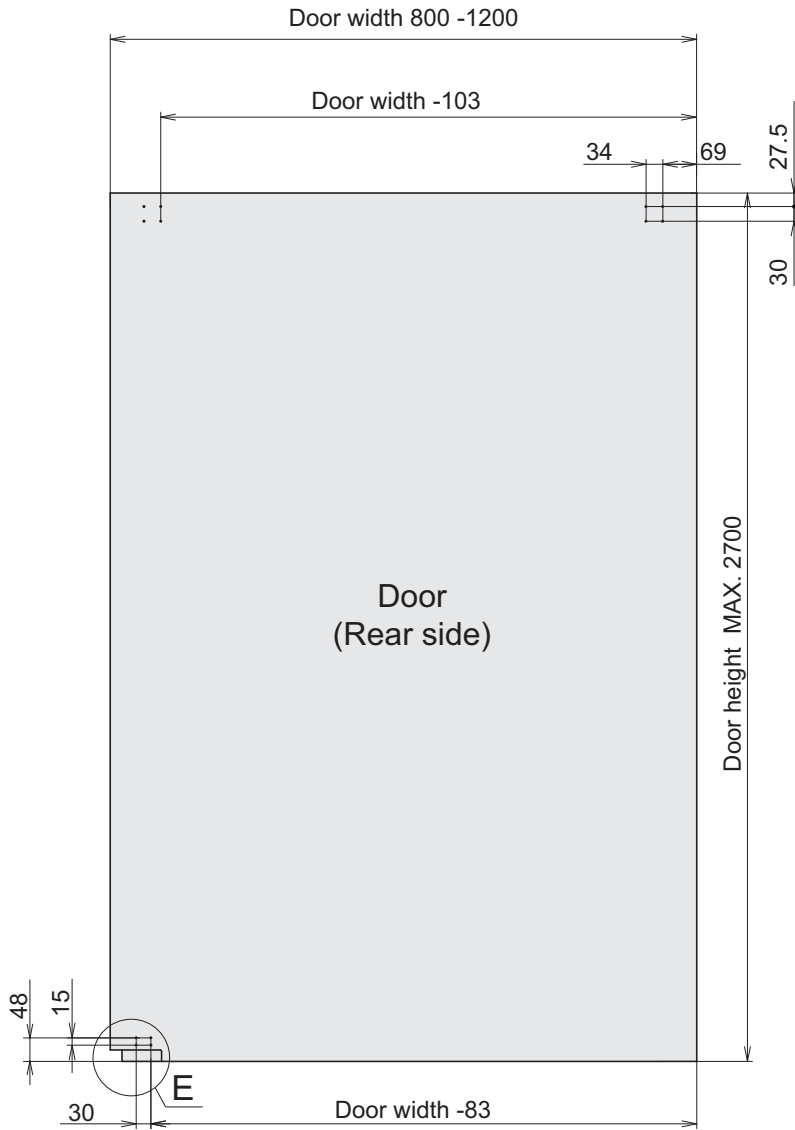

# INSTALLATION

A left to right opening door is used as an example.

## 1 Cutting Track and Hole Drilling on Upper Track

No need to process the track if its length is 1200 mm.

### ⚠ CAUTION

- ❗ When cutting, reinforce the track to prevent deformation at the cut section.
- ⊘ Do not process upper track B.

#### ■ Upper track A ( leading edge)

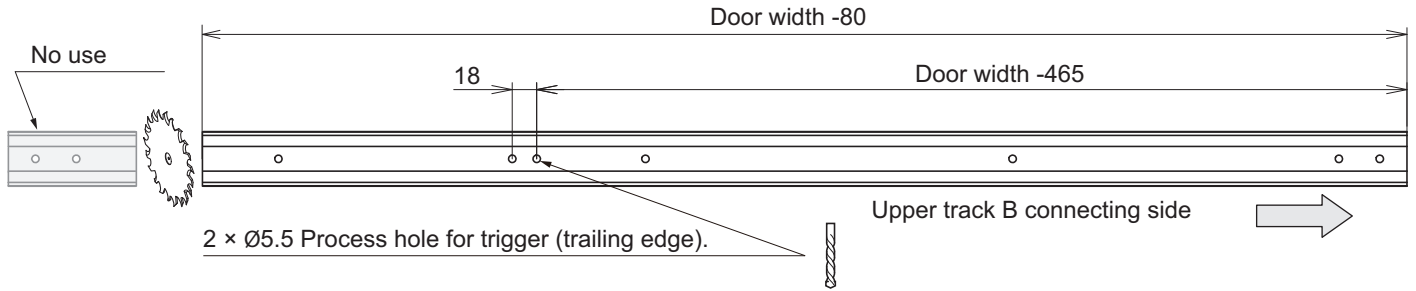

When frame opening width is 1675 - 1849 mm.

### ⚠ CAUTION

- ❗ In this case, the track length for the leading edge will be different from the length of the trailing edge. So, please do not misplace the tracks.

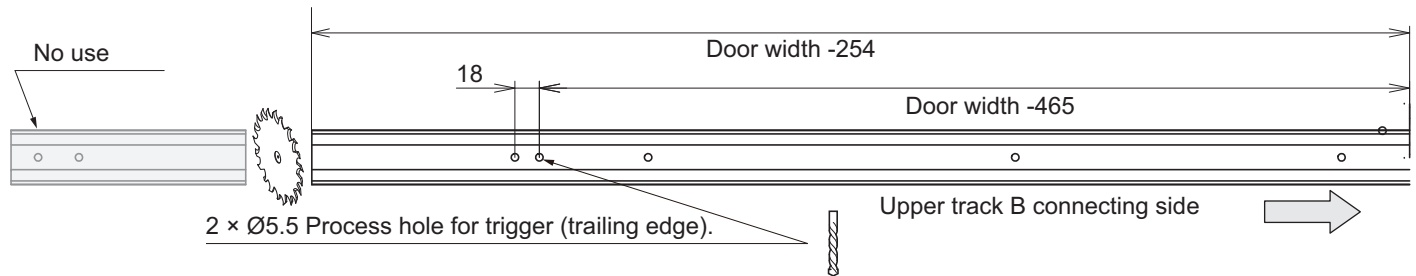

#### ■ Upper track A ( trailing edge)

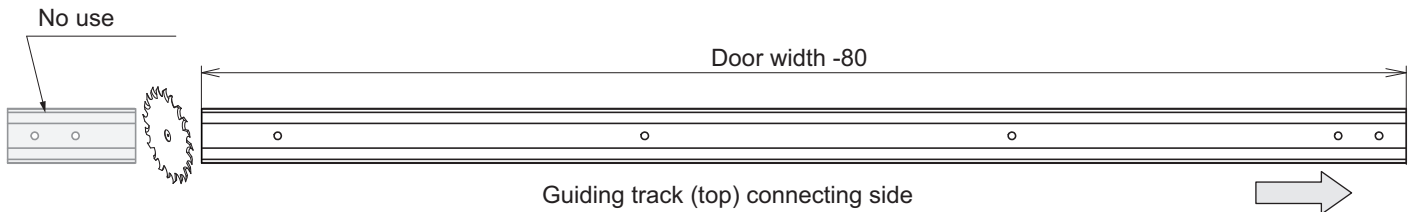

#### ■ Bottom track

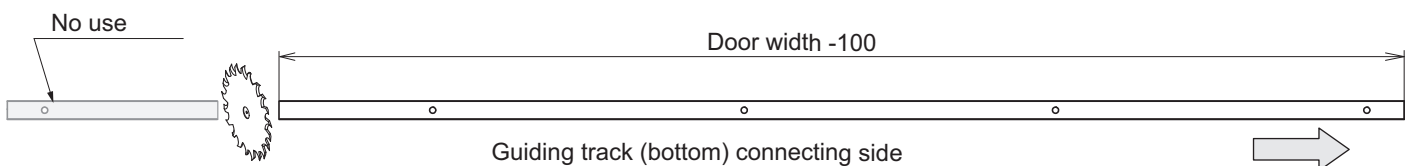

## 2 Mounting parts on the Door

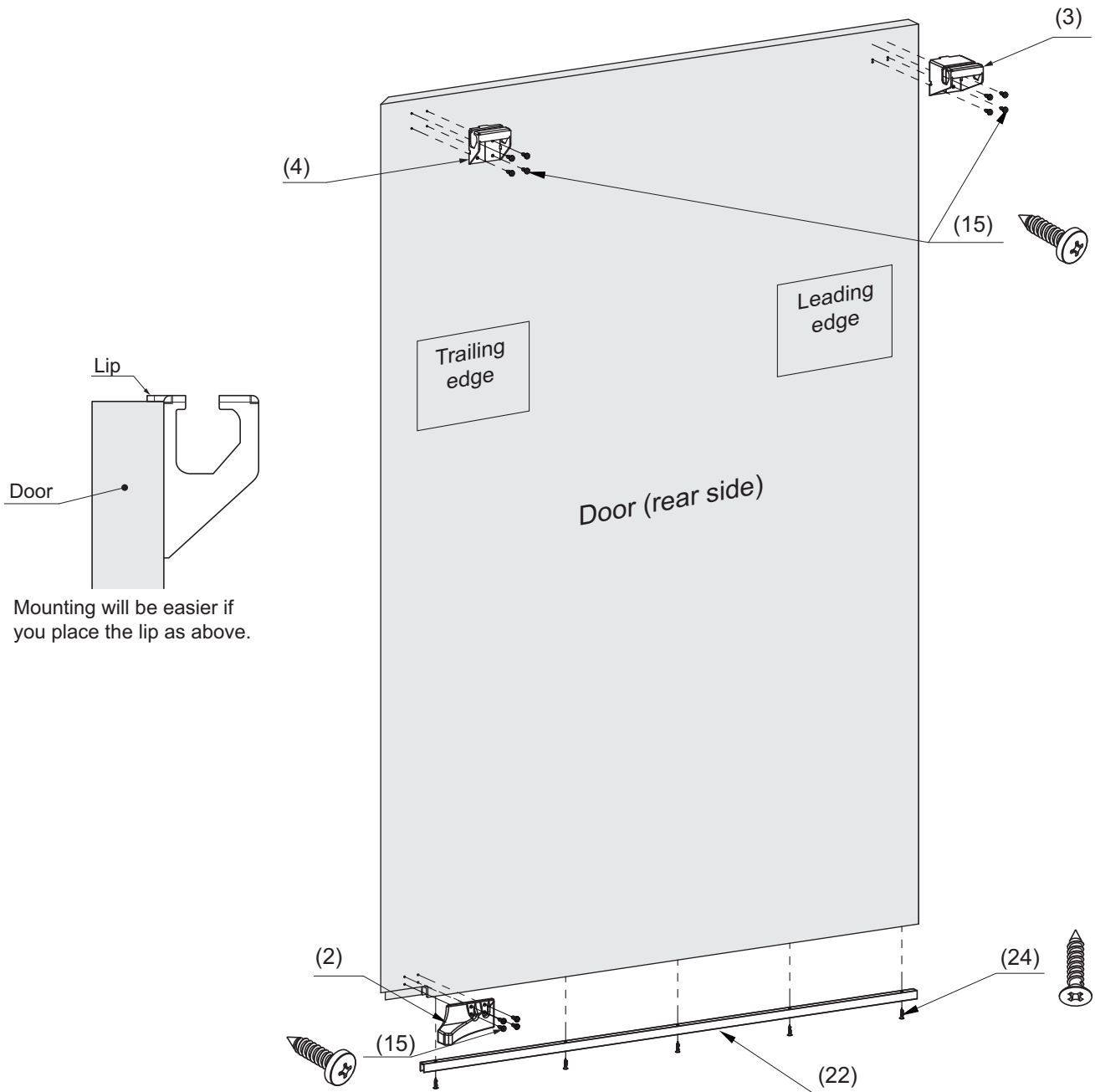

### ⚠ CAUTION

❗ Leave no gap on the connecting part.

OK

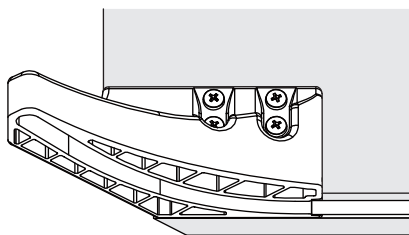

×

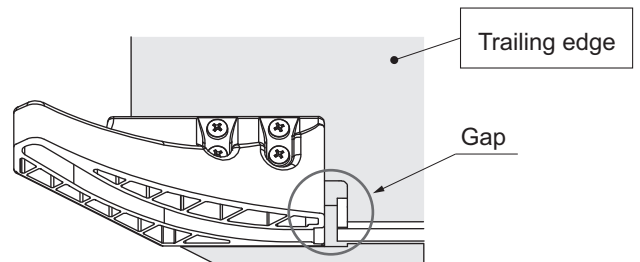

### 3 Mounting of Upper Track B and Connecting Plate

#### ⚠ CAUTION

❗ Remove any dirt or aluminum chips from the track.

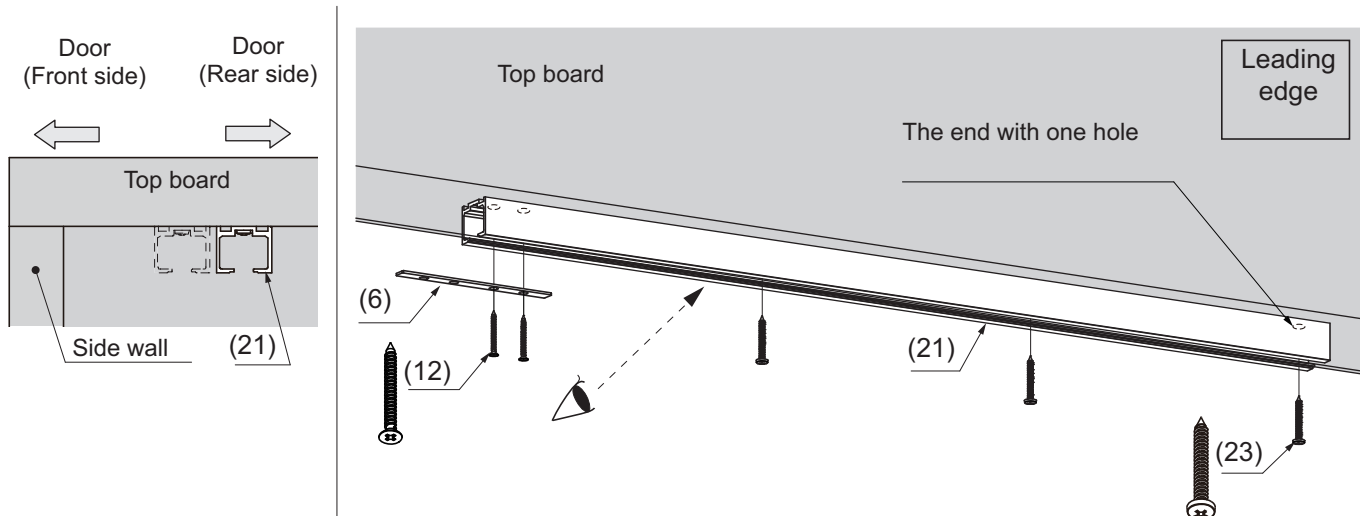

### 4 Verification Before Installing the Soft Closer

#### ⚠ CAUTION

⚠ Without verification the self closing feature may fail.

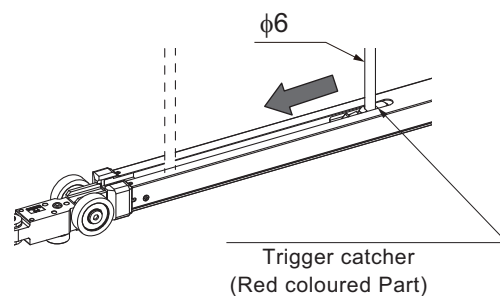
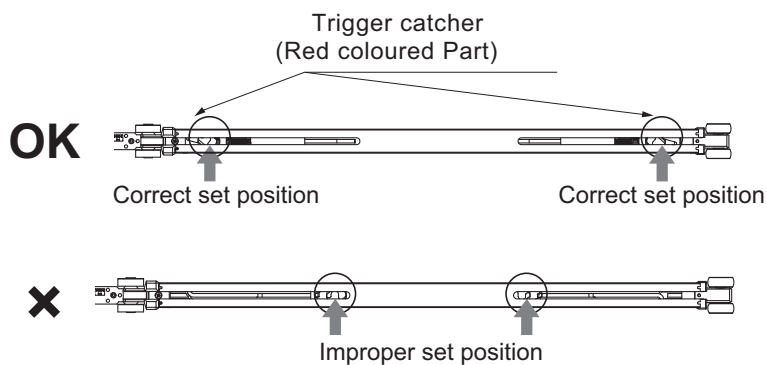

If the trigger position is wrong, pull back the trigger catcher to the correct position using a 6mm diameter round bar.

### 5 Inserting Soft Closer into Upper Track B

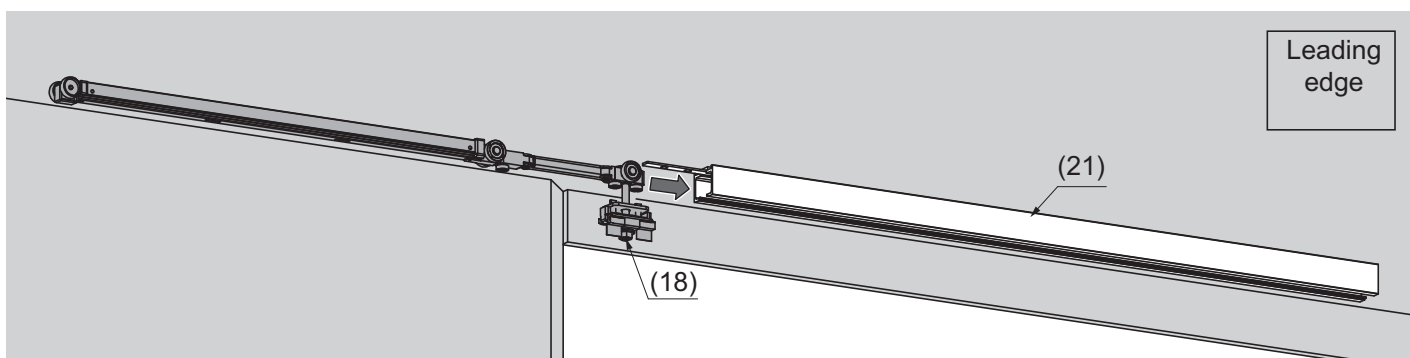

## 6 Mounting of Upper Track A

### ■ Upper track A (leading edge)

#### 1 **CAUTION**

- ❗ Remove any dirt or aluminum chips from the track.
- ❗ Face the cut end towards the trailing edge.

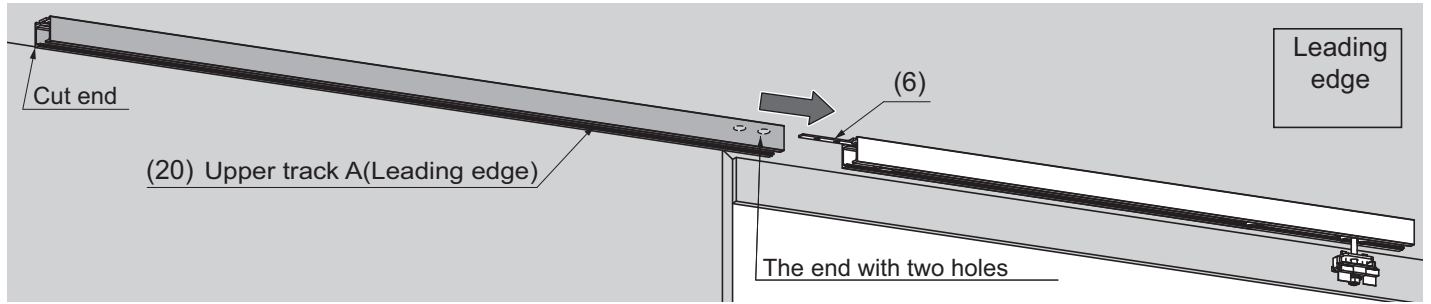

#### 2 **CAUTION**

- ❗ Keep holding the track until screwing is finished.
- ❗ Be careful not to misalign the tracks. Tighten the screws firmly to leave no gap.

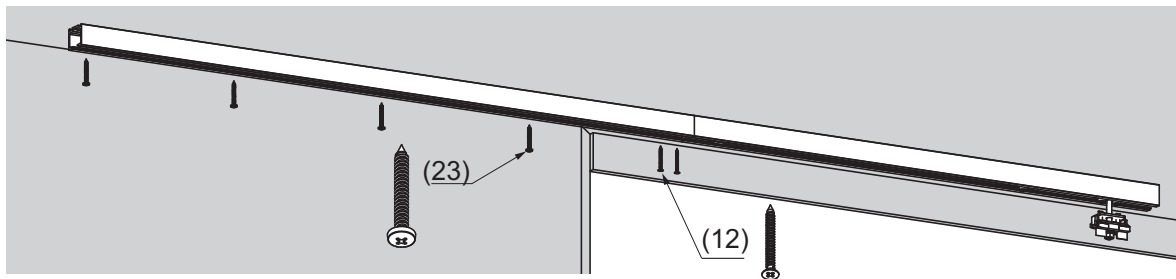
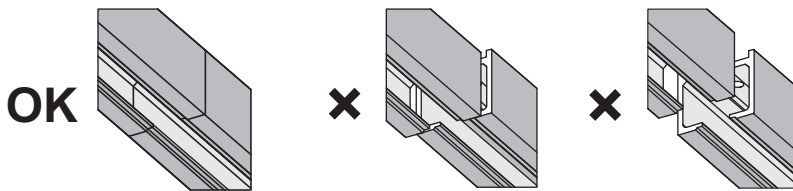

### ■ Upper track A (trailing edge)

#### **CAUTION**

- ❗ Face the cut end to the trailing edge.

Door (Front side)    Door (Rear side)

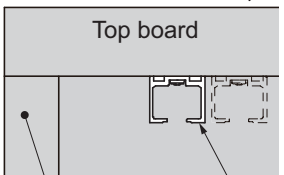

(20) Upper track A (trailing edge)

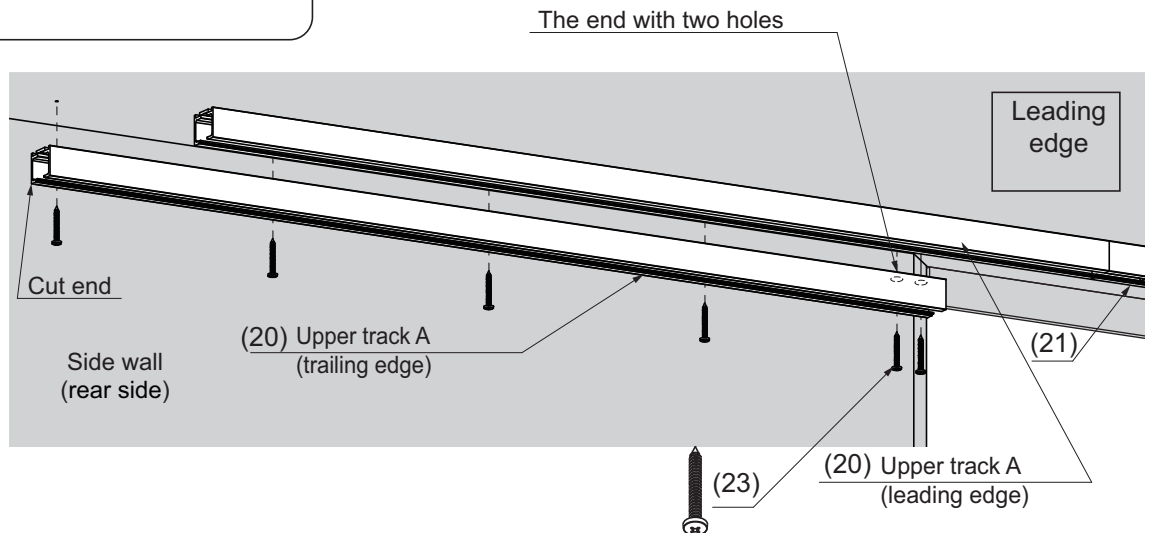

## 7 Mounting of Guiding Track (top)

1

### ⚠ CAUTION

- ❗ Be careful not to misalign the tracks.  
Tighten the screws firmly to leave no gap.

OK

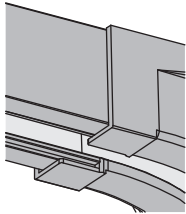

×

Gap

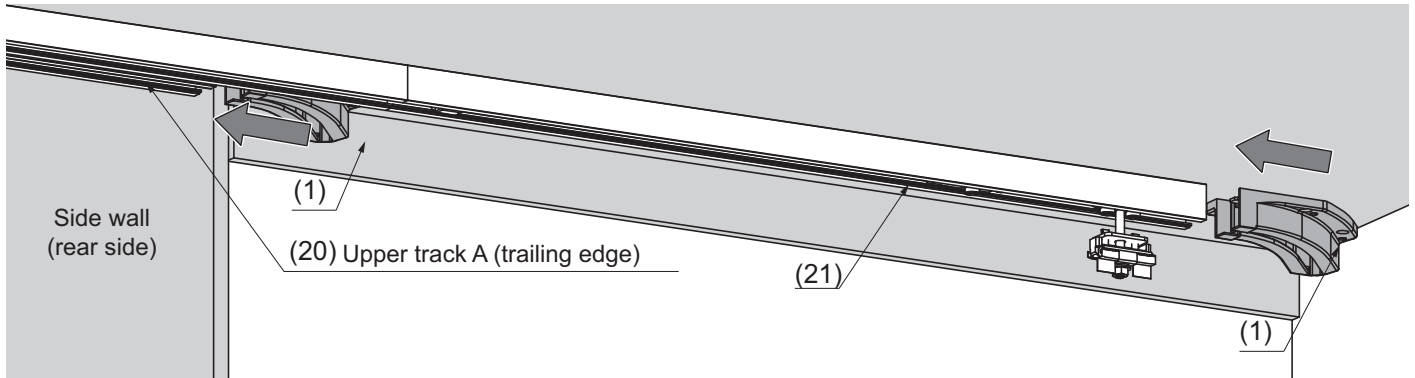
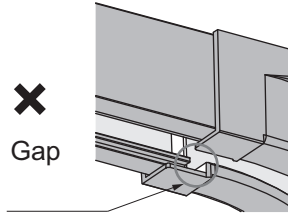

2

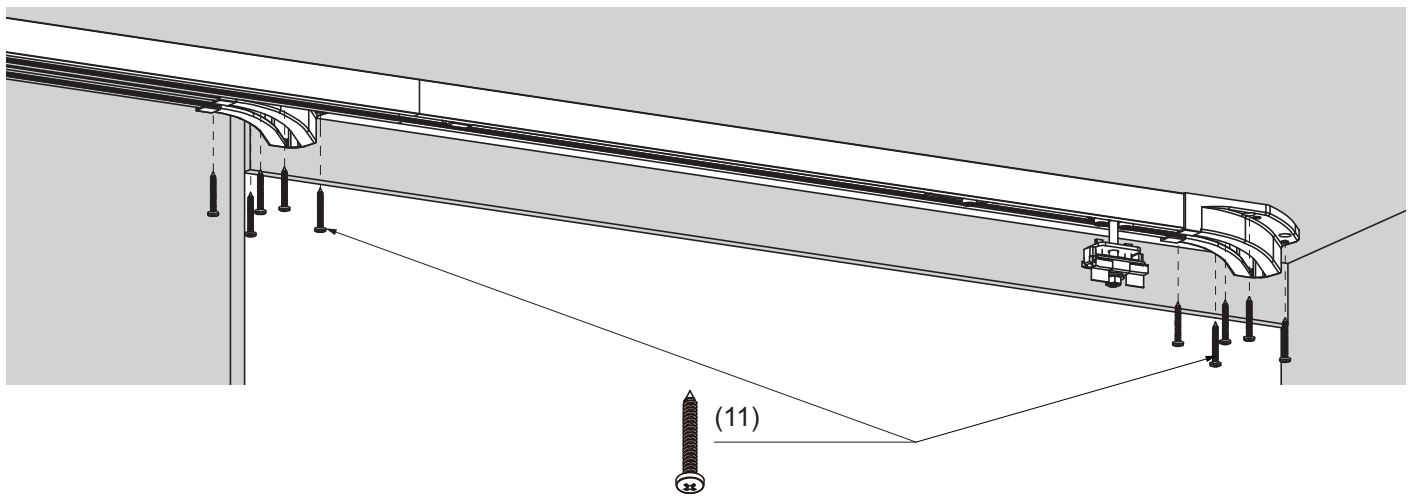

## 8 Inserting Upper Roller into the Upper Track A (trailing edge)

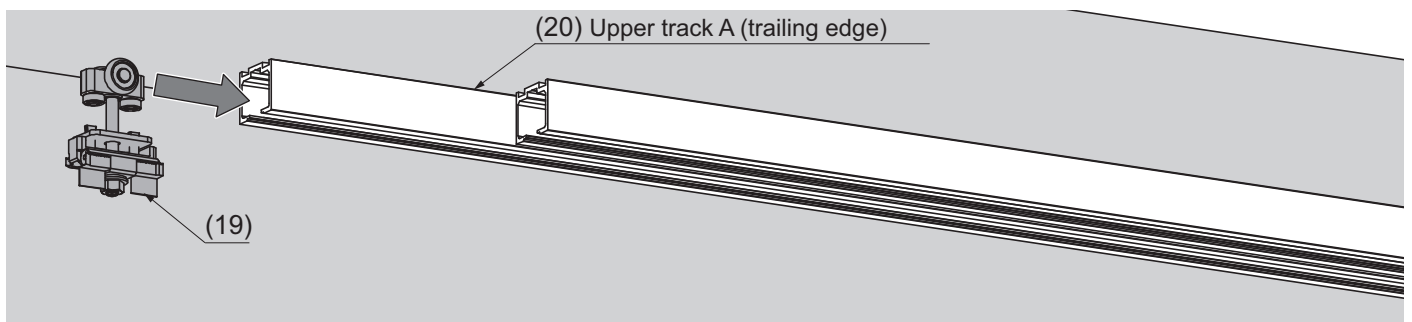

## 9 Mounting of the Trigger

Mount the triggers on the upper track A (leading edge) and Upper track B.

1 Assemble trigger to jig.

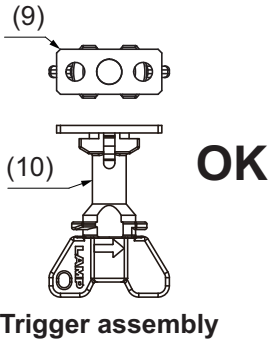

2 Align trigger with the holes.

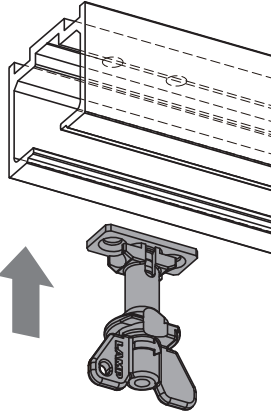

3 Turn the jig 90° and fix the trigger.

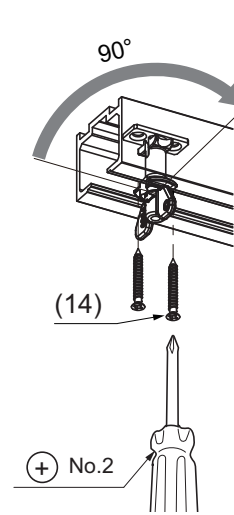

4 Remove the jig.

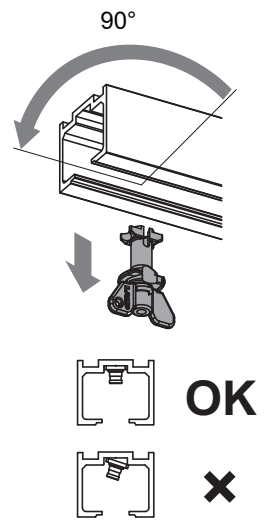

## 10 Mounting of the Bottom Guide

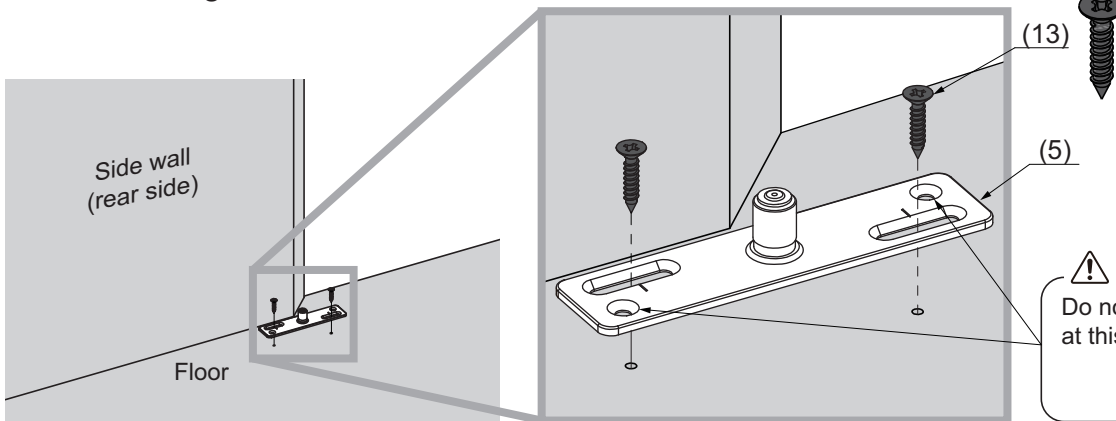

## 11 Hanging Door

1 Put the door on the support, then place the groove of the bottom track on the protruding part of the floor guide.

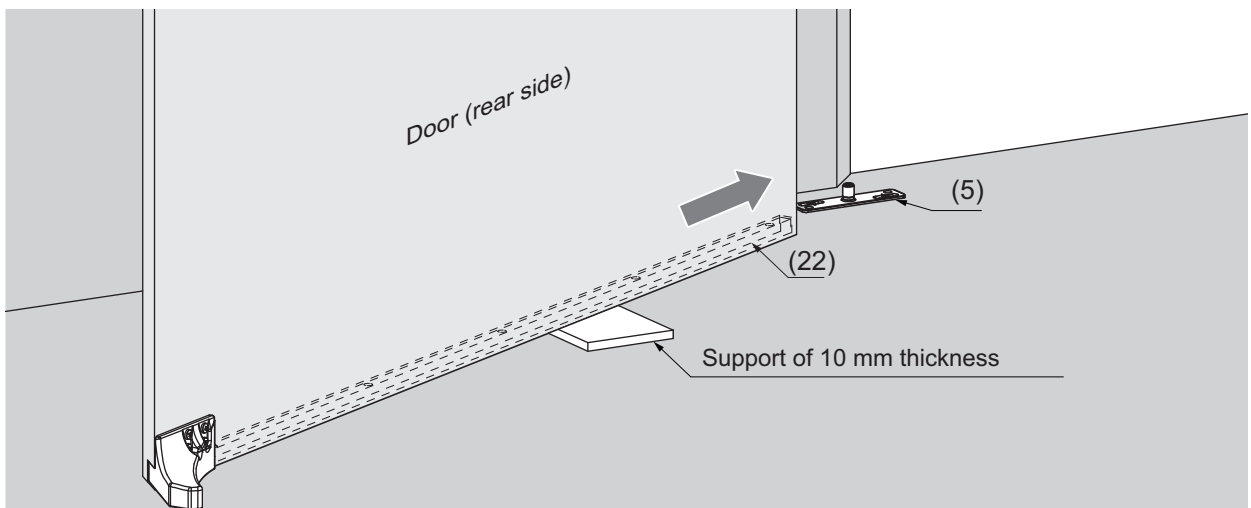

**2** Slide the Soft Closer (leading edge) into the Bracket (leading edge)

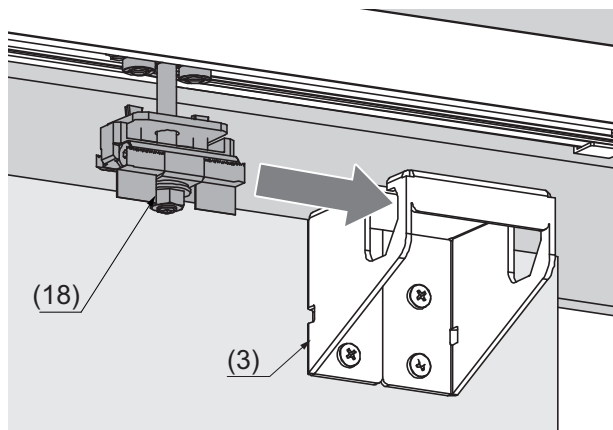

**CAUTION**

Do not remove the tape before inserting, since it makes the work difficult.

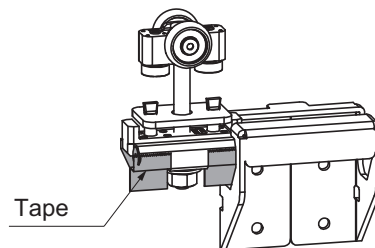

Slide the Soft Closer (trailing edge) into the Bracket (trailing edge)

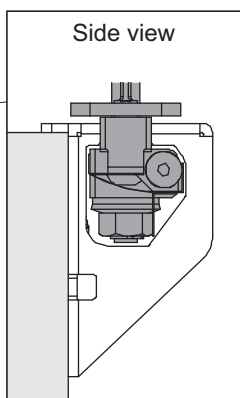
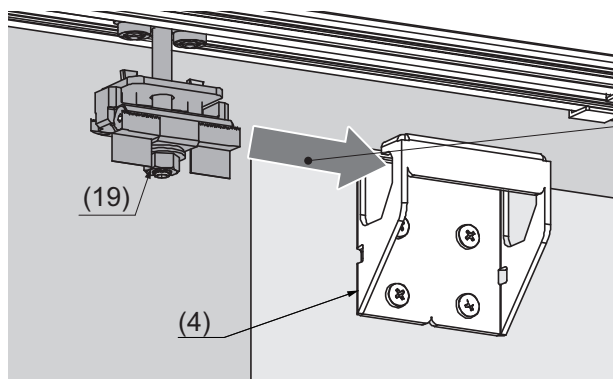

**3** Hanging

The figures show the procedure for the leading edge (18). The procedure for the trailing edge (19) will be the same.

(1) Remove the tapes.

(2) Loosen the fastening nut for 360°.

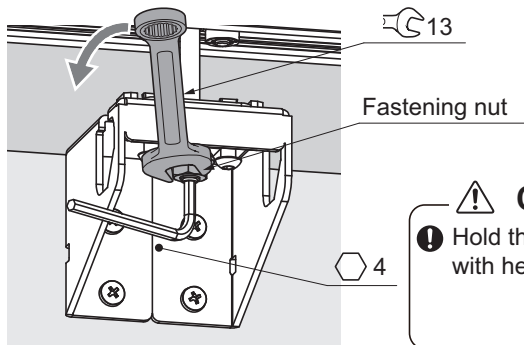
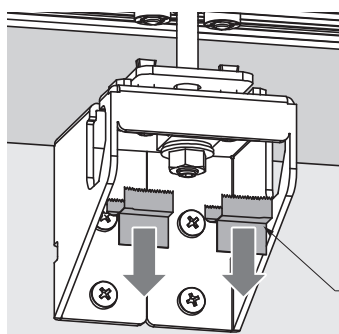

**CAUTION**

Hold the vertical adjustment screw with hex key.

(3) Turn the screw to raise the door from the support.

(4) Tighten the fastening nut

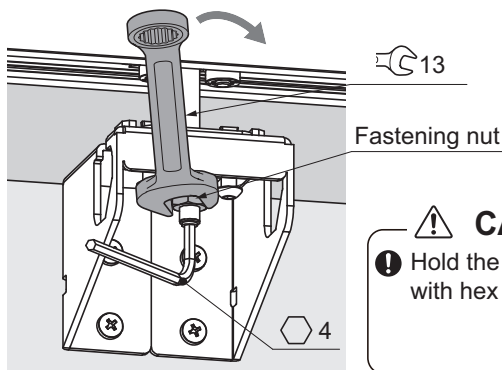
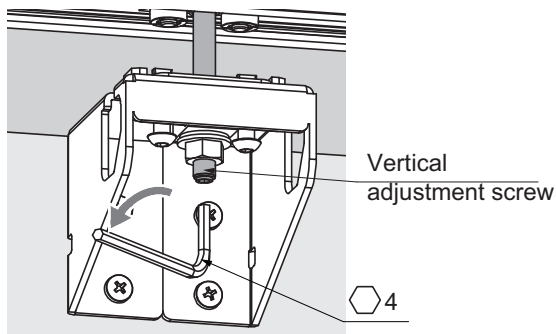

**CAUTION**

Hold the vertical adjustment screw with hex key.

(5) Tighten the fastening bolt

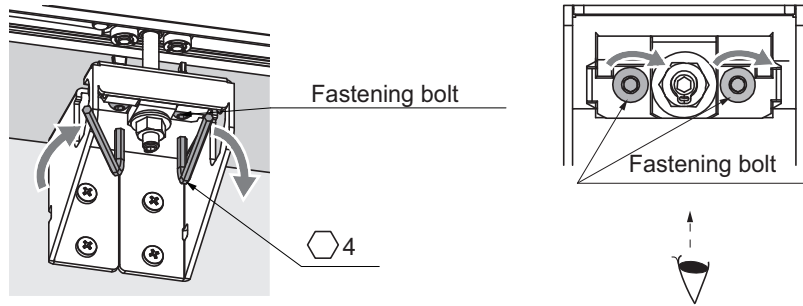

## 12 Door Adjustments

### ⚠ CAUTION

- ❗ Move door slowly so as not to go out of tune.
- ❗ Be sure to make adjustments in the orders of following procedure.
- ⚠ We recommend that the adjustment be made by two people, since the door position needs to be checked from outside.

### ■ Adjusting points and ranges

3 Depth adjustment (Bottom of trailing edge) P.19

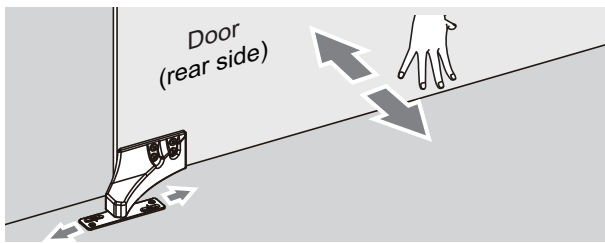

2 Depth adjustment (Leading edge) P.18

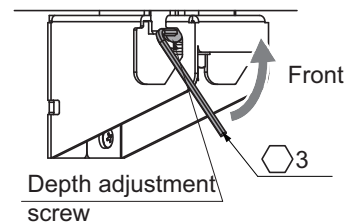

4 Depth adjustment (Bottom of leading edge) P.20

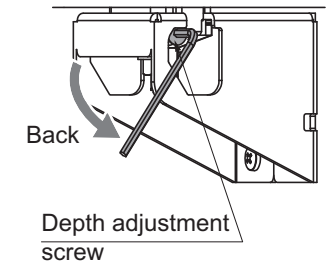
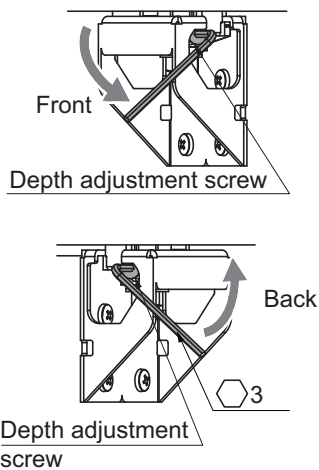

1 Vertical adjustment P.17

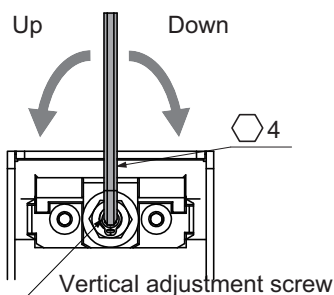

1 Vertical adjustment P.17

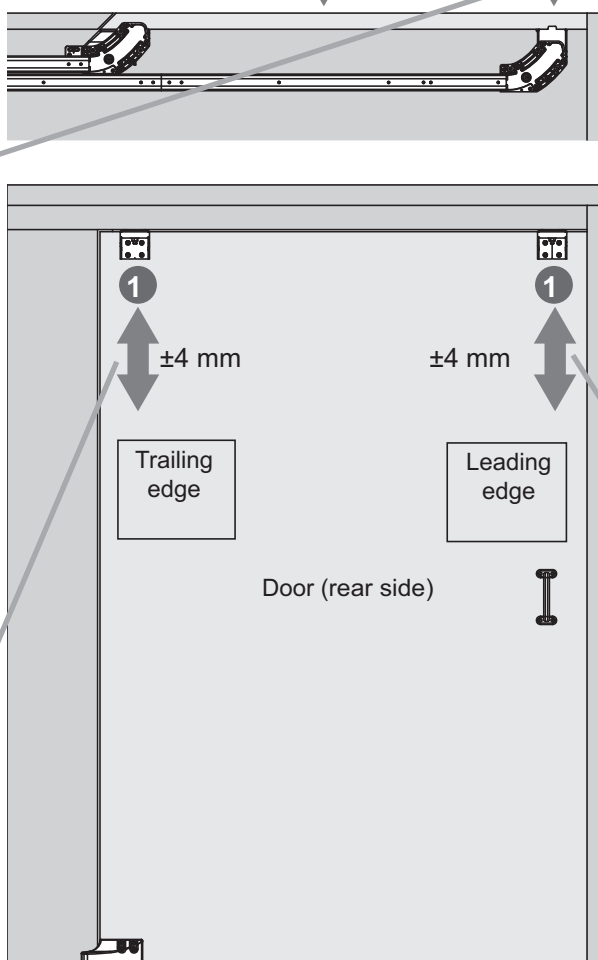
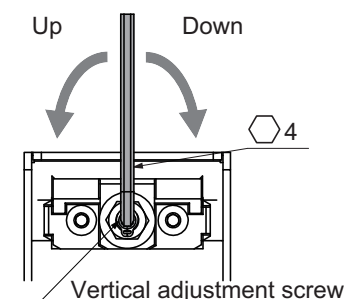



## 2 Depth adjustment (Top of leading edge)

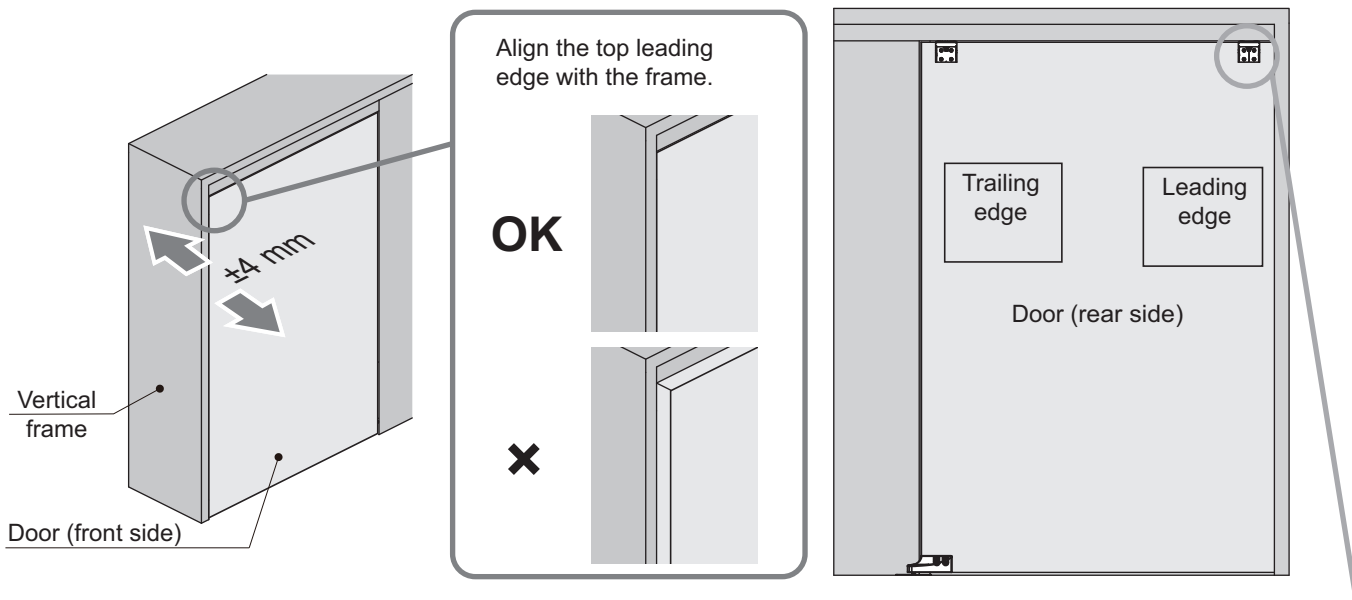

### Move forward

(1) Turn the adjustment screw until it hits the bracket (for leading edge).

(2) To move the door forward, turn the depth adjustment screw and move the soft closer (leading edge) to the right.

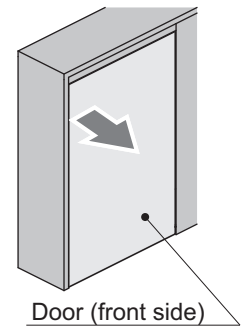
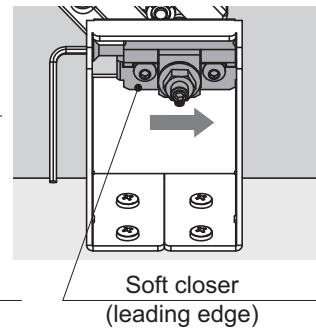
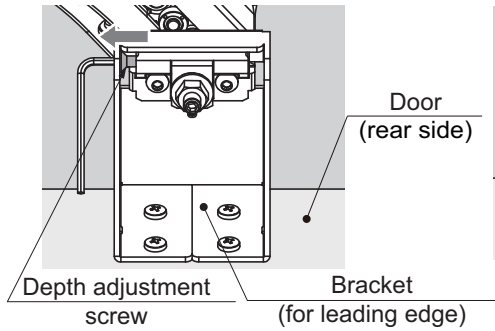
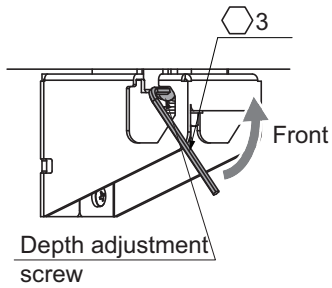

### Move backward

(1) Turn the adjustment screw until it hits the bracket (for leading edge).

(2) To move the door backward, turn the depth adjustment screw and move the soft closer (leading edge) to the left.

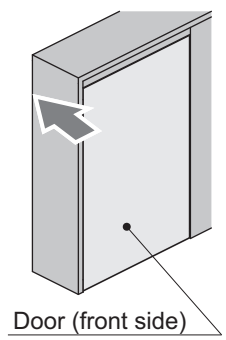
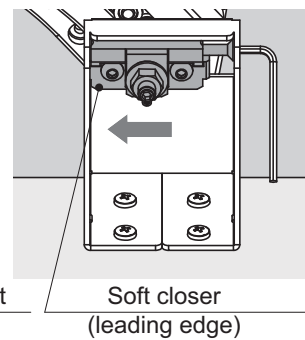
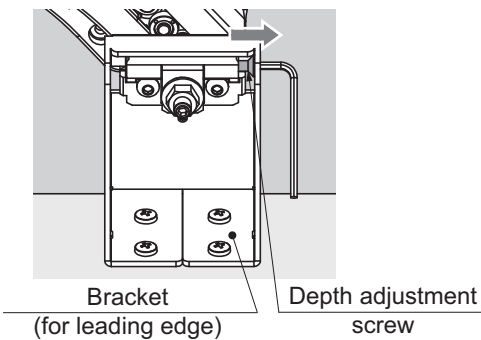
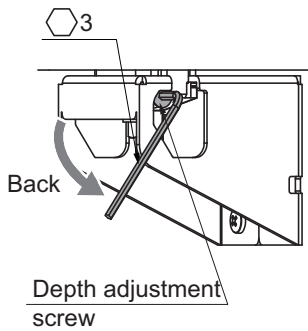

### When readjusting

First, turn the screw opposite of the side to be adjusted and create a space for adjustment, then turn the screw to adjust forward or backward.

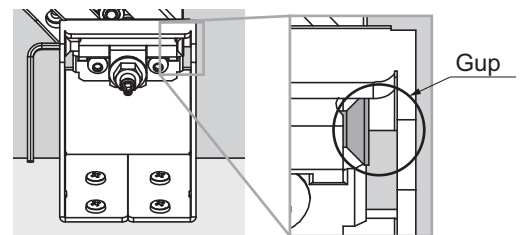

3 Depth adjustment (Bottom of trailing edge)

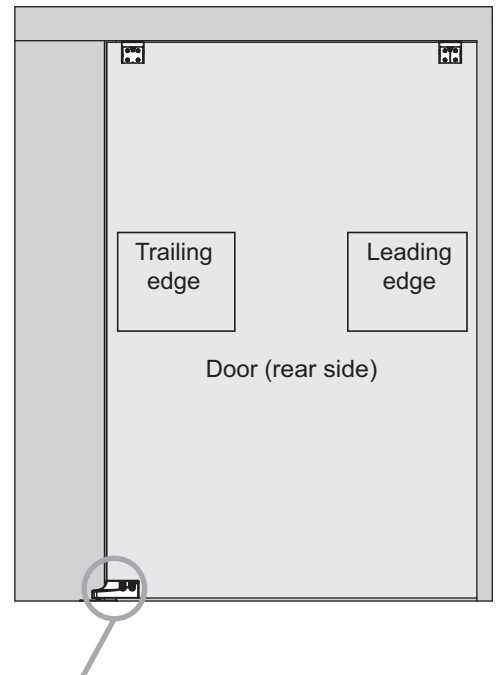
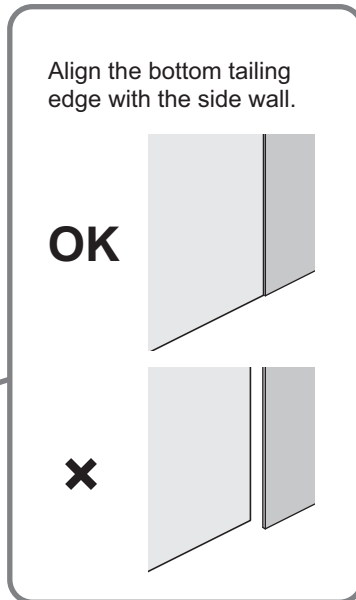
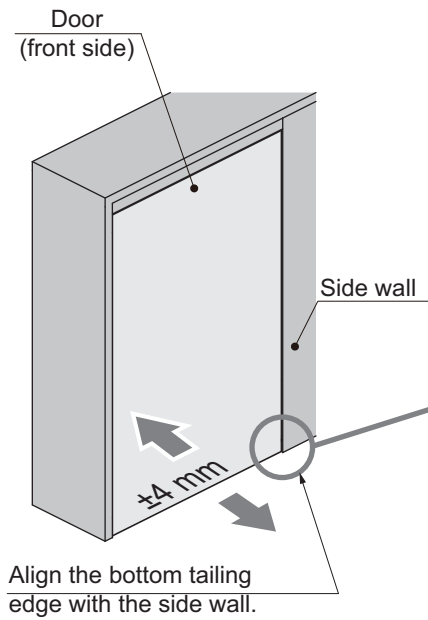

(1) Loosen the screws.

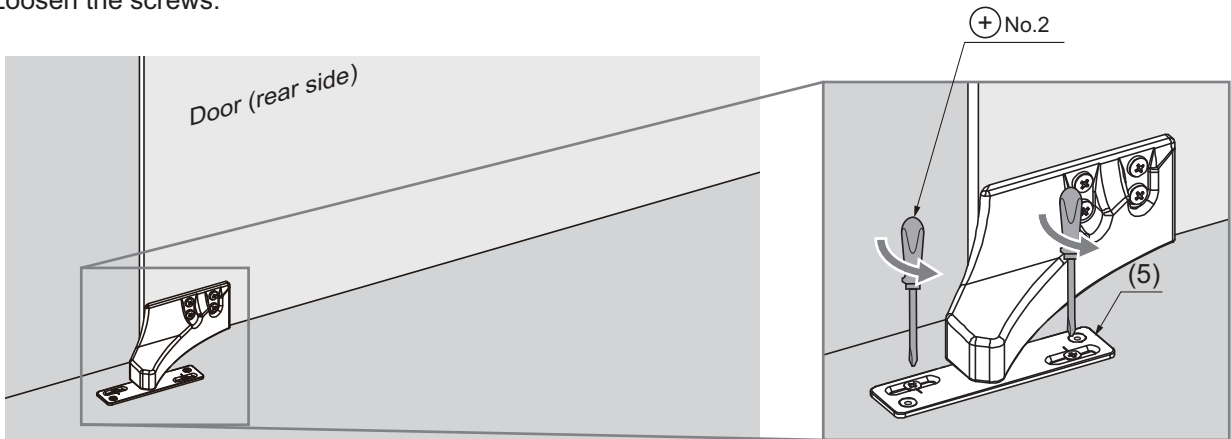

(2) Push the door and make it flash with the side wall.

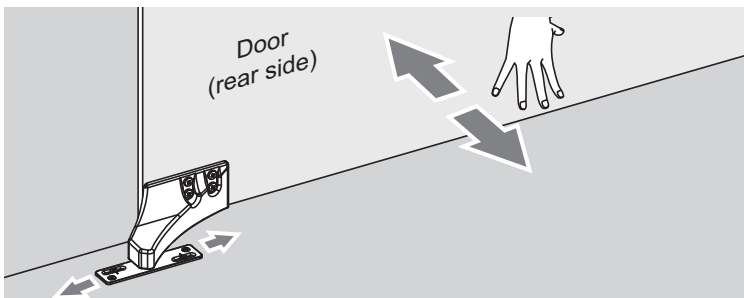

(3) Tighten the screws.

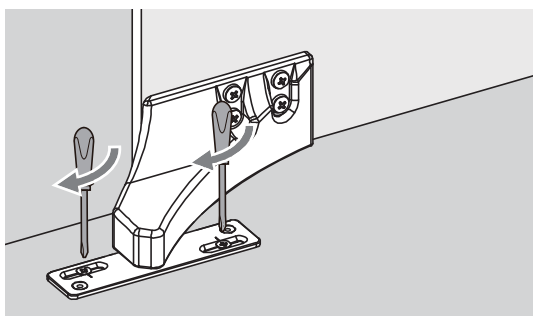

(4) Fasten the rest two holes with screws.

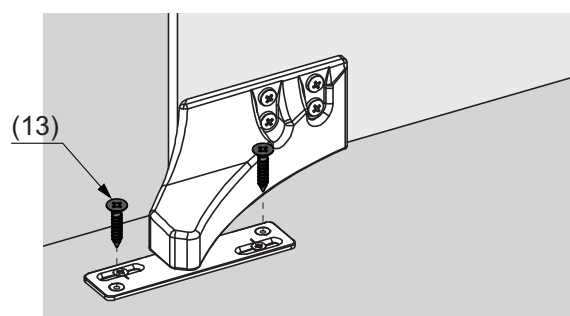

#### 4 Depth adjustment (Bottom of leading edge)

Door (front side)

Vertical frame

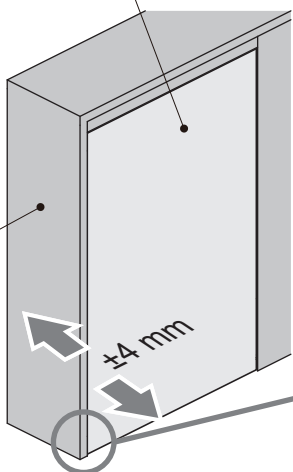

Align the bottom leading edge with the frame.

OK

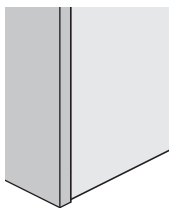

X

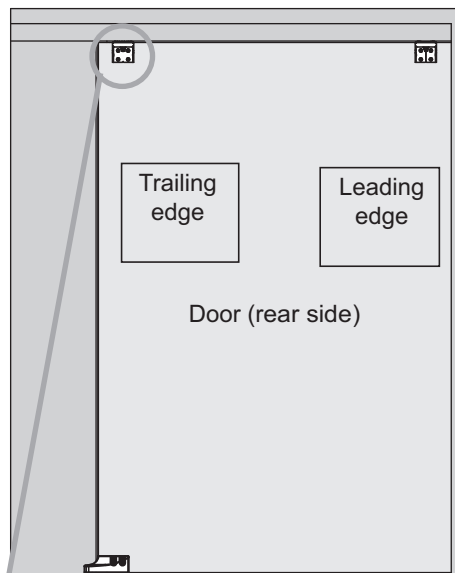
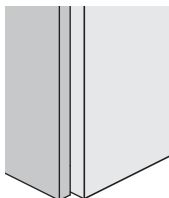

Trailing edge

Leading edge

Door (rear side)

Move forward

3

Front

Depth adjustment screw

(1) Turn the adjustment screw until it hits the bracket (for trailing edge).

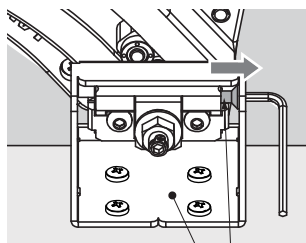

Bracket (for trailing edge)

Depth adjustment screw

(2) To move the door forward, turn the depth adjustment screw and move the soft closer (trailing edge) to the left.

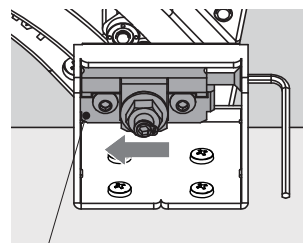

Door roller (trailing edge)

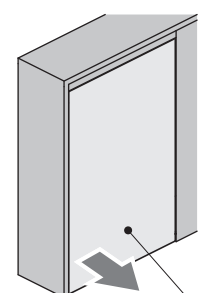

Door (front side)

Move backward

3

Back

Depth adjustment screw

(1) Turn the adjustment screw until it hits the bracket (for trailing edge).

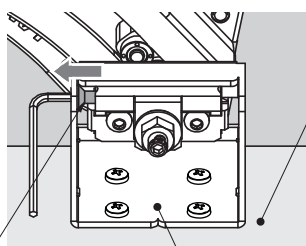

Depth adjustment screw

Bracket (for trailing edge)

(2) To move the door backward, turn the depth adjustment screw and move the soft closer (trailing edge) to the right.

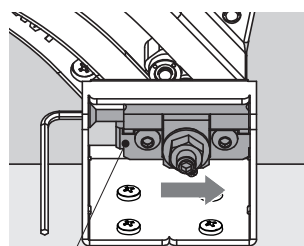

Door roller (trailing edge)

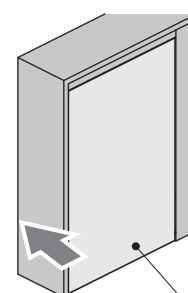

Door (front side)

When readjusting

First, turn the screw opposite of the side to be adjusted and create a space for adjustment, then turn the screw to adjust forward or backward.

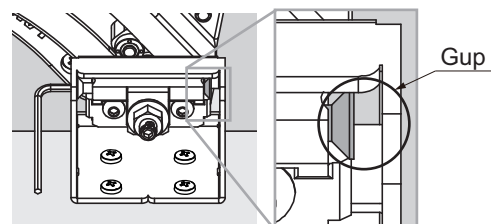

Gup

If the adjustment cannot be done completely, check if the door is warped, or check the parts mounting positions are correct.

**5** Tighten the fastening nut after the adjustment.

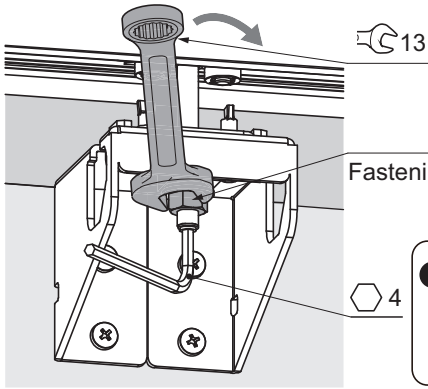

Fastening nut

4

**CAUTION**

Hold the vertical adjustment screw with allen key.

**6** Tighten the fastening bolts.

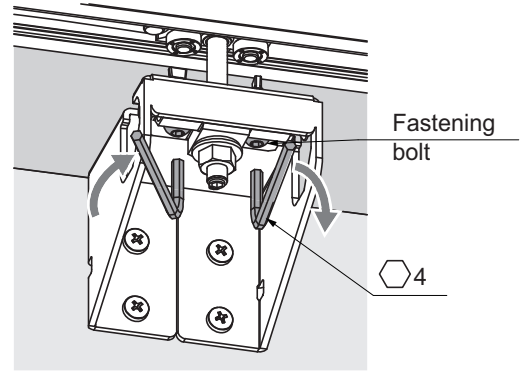

Fastening bolt

4

**7** Press the heads of Depth adjustment screws to the bracket (3)(4)

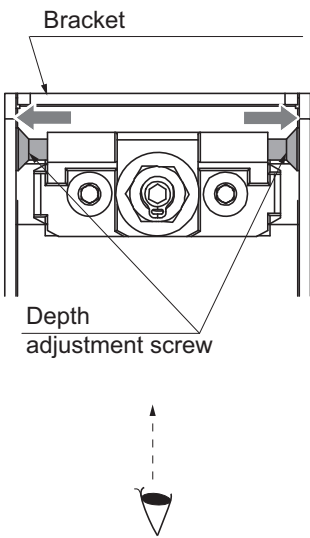

Bracket

Depth adjustment screw

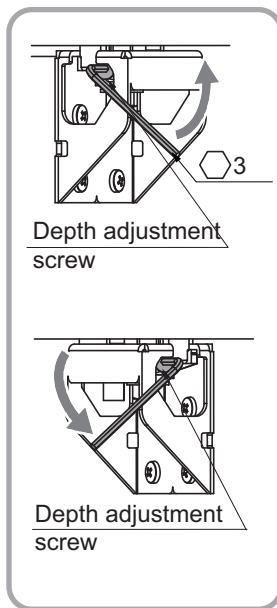

Depth adjustment screw

Depth adjustment screw

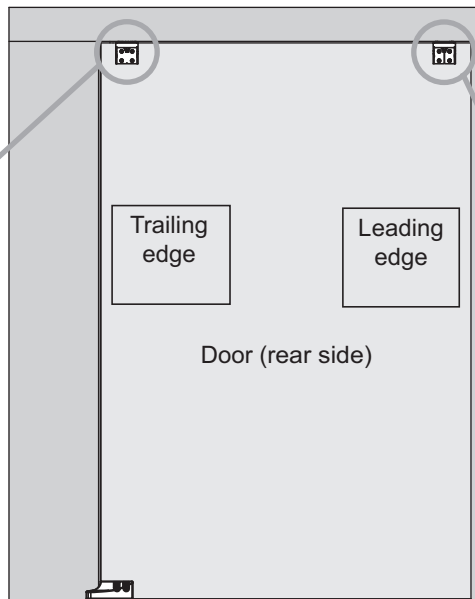

Trailing edge

Leading edge

Door (rear side)

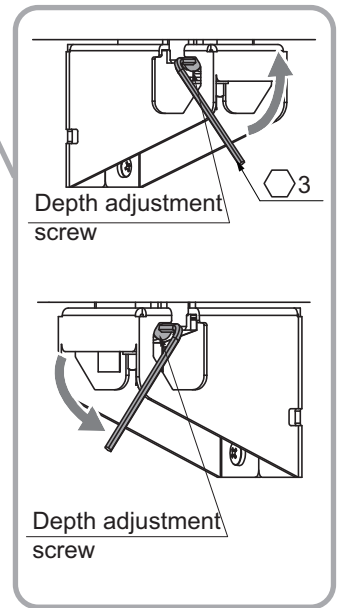

Depth adjustment screw

Depth adjustment screw

**8** Check the door movement, then check if there's any screw or nut loosened.

**13** Mounting of Door Stopper (Floor)

(7) Door stopper (floor)

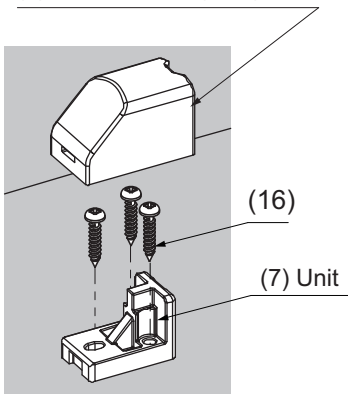

(16)

(7) Unit

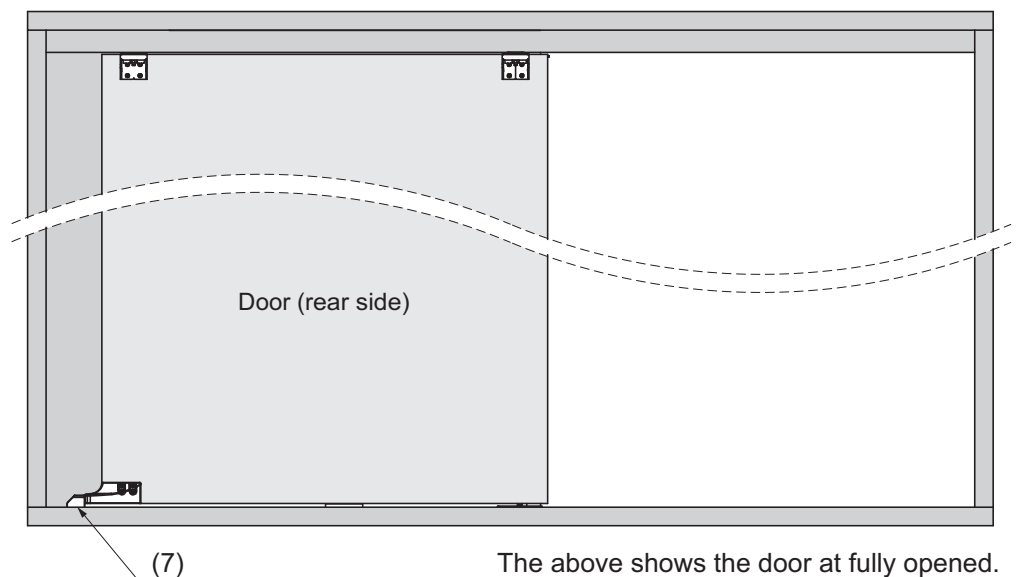

Door (rear side)

(7)

The above shows the door at fully opened.

## 14 Fastening of Bumper Block

1 Loosen the screw, then insert the bumper block into the upper track A (trailing edge).

2 Slide the bumper block until it touches the door roller.

3 Fasten the screw.

(20) Upper track A  
(trailing edge)

(8)

screw

⊕ No.2

(19)

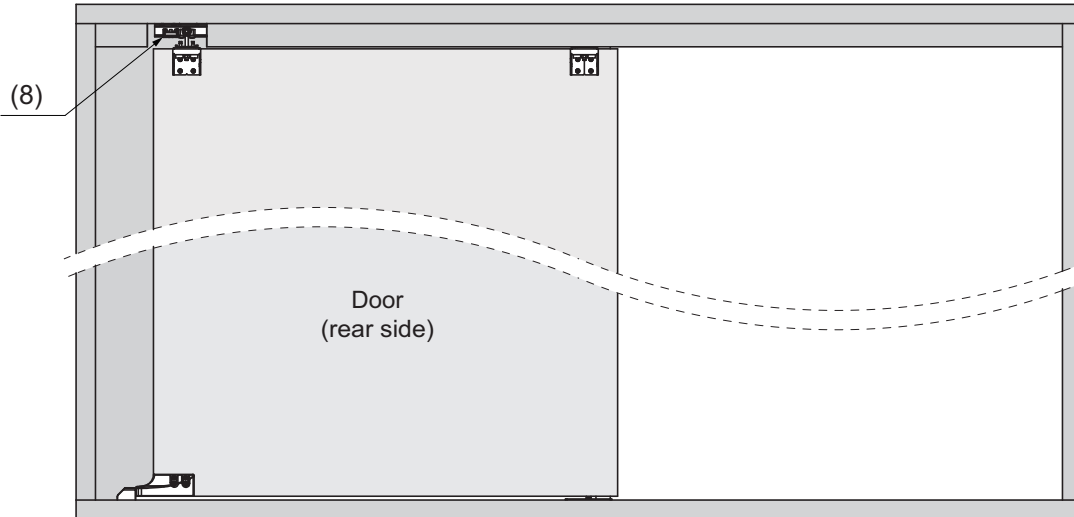

The above shows the door at fully opened.

## 15 Pasting the Caution Sticker

Paste the caution sticker to a prominent place on the door.

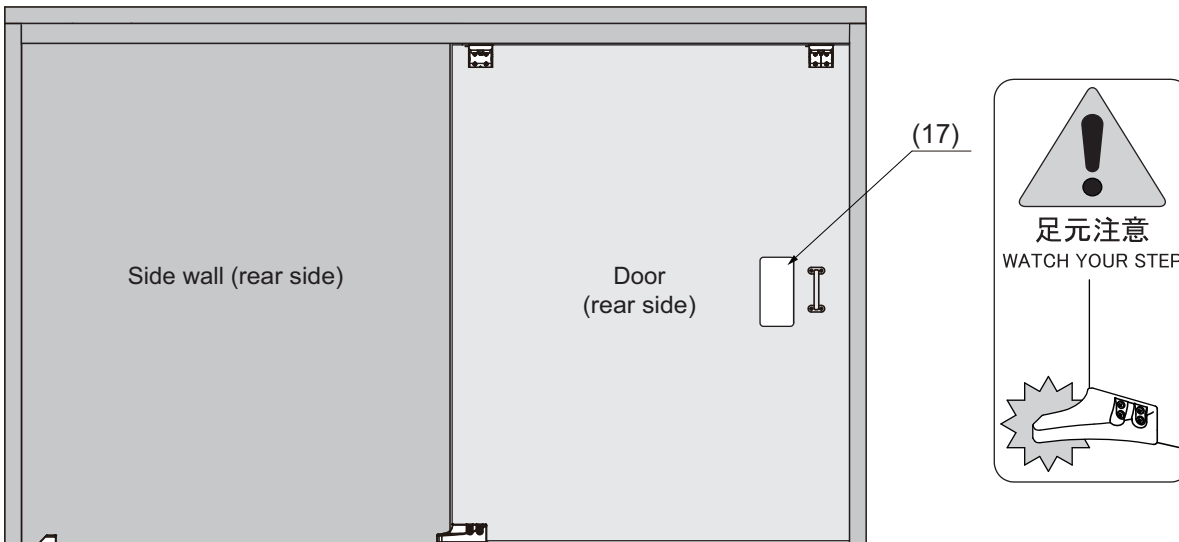

Final verification	Verify that all screws are securely tightened, and verify that all screws have been used.
PERIODICAL INSPECTION	Clean inside of track.
	Check upper and lower gaps between the door and frame. If necessary, adjust the gaps.

## TROUBLE SHOOTING

Trouble	Checkpoint	Solution
Door stops during soft closing	Check if bottom of the door contacts the floor or if the bottom track catches the floor guide. Also check if the bottom track catches the floor guide.	Verify that the track mounting screws are not loosened. Then, adjust the door height such that the clearance between the door bottom and floor is 10 mm (Ref. to section <b>12</b> ). ①
	Check if the room where the track installed is a closed chamber.	Install a ventilator to relieve the air.
	Check if the upper track or guiding track (top) are set horizontally.	Using a level gauge, reset the upper track and guiding track horizontally.
	Check if door touches the side wall.	Adjust the door depth position to backward (Ref. to section <b>12</b> ). ③
No soft closing	Check if trigger is installed.	Install trigger to correct position.
	Check if door is closed or opened by excessive force.	Do not close or open the door by excessive force as it may damage the soft closer.
	The position of the trigger catcher may become dislocated. (It is hidden as installed in upper track.)	Remove the door and the upper track, then check the status of the trigger catcher in section <b>4</b> .
Abnormal noise during operation	Check if bottom of the door contacts the floor or if the bottom track catches the floor guide. Also check if the bottom track catches the floor guide.	Verify that the track mounting screws are not loosened. Then, adjust the door height such that the clearance between the door bottom and floor is 10 mm (Ref. to section <b>12</b> ). ①
	Check track rollers for aluminum dust.	Remove the track, then pull out and clean the roller.
	Check if door is warped.	If the door is warped, use anti-warping fitting or replace the door.
	Check if door touches the side wall.	Adjust the door depth position to backward (Ref. to section <b>12</b> ). ③
	Check if the fastening screws are loosened.	Fasten the screws.
	Check the tracks if there's any gap or unevenness at the jointed parts.	Re-mount the tracks not to leave any gap nor unevenness at the jointed parts.
	The fastening nut and the fastening bolt may not be tightened.	Tighten the fastening nut and the fastening bolt.
Heavy door operation	Check if bottom of the door contacts the floor or if the bottom track catches the floor guide. Also check if the bottom track catches the floor guide.	Verify that the track mounting screws are not loosened. Then, adjust the door height such that the clearance between the door bottom and floor is 10 mm (Ref. to section <b>12</b> ). ①
	Check if door is warped.	If the door is warped, use anti-warping fitting or replace the door.
	Check if door touches the side wall.	Adjust the door depth position to backward (Ref. to section <b>12</b> ). ③
Door does not move	Check the track mounting screws for looseness.	Retighten the screws to free the roller.
Door starts to move	Check if the upper track is set horizontally.	Using a level gauge, reset the upper track horizontally.
Door stops or is caught during operation	Check the tracks if there's any gap or unevenness at the jointed parts.	Re-mount the tracks not to leave any gap nor unevenness at the jointed parts.
Door cannot be opened fully	Are there any obstacles in contact with the guiding track (bottom)?	Remove the obstacles.